

August 2023

# Lease Improvement Manual

Commerce Court





# Table of Contents

SECTION 1.0 - INTRODUCTION .....	8
1.1 CONSTRUCTION SERVICES .....	9
1.2 PROPERTY MANAGEMENT CONTACTS .....	9
1.3 LANDLORD APPROVED CONSULTANTS.....	10
Architect .....	10
Structural .....	10
Mechanical and Electrical.....	10
Asbestos and Environmental .....	11
Security Systems .....	11
Life Safety & Suppression System .....	11
Communications/Riser Management .....	11
Commissioning Services .....	11
1.4 REGULATORY BODIES.....	12
1.5 LANDLORD APPROVED CONTRACTORS .....	12
Mechanical.....	12
Security Systems (Access Control Readers, CCTV And Alarms).....	13
Fire Alarms .....	13
Sprinklers.....	14
Locksmith .....	14
Asbestos Removal .....	14
Communications /Riser Management .....	15
SECTION 2.0 - TENANT DESIGN,WORKING DRAWINGS & WORK ADMINISTRATION PROCESS ....	16
2.1 SUSTAINABLE TENANT DESIGN .....	16
2.1.1 Sustainable Tenant Design: The Bottom Line .....	17
2.3 TENANT CONSULTANTS.....	18
2.4 APPROVAL OF TENANT DRAWINGS.....	18
2.4.1 Submission of Preliminary Drawings .....	18
2.4.2 Submission of Final Plans and Specifications .....	18
2.4.3 Drawing Revisions.....	20
2.4.4 Specifications .....	20



2.4.5 Drawing Review.....	20
2.4.6 Permits.....	20
2.4.7 Contactors .....	20
2.5 WORK ADMINISTRATION PROCESS .....	21
2.5.1 Documents Required Prior to Work Permit Approval and Commencement of Work .....	21
2.5.2 Documents Required during Work.....	22
2.5.3 Documents Required Following the Completion of Work (also refer to Section 3.11).....	22
SECTION 3.0 - PROCEDURES & REGULATIONS .....	23
3.1 ABOVE CEILINGWORK .....	23
3.2 ACCESS PANELS.....	24
3.3 AIR BALANCE REPORT.....	24
3.4 AIR INTAKE (BREATHER).....	24
3.5 AMENDMENTS TO LEASEHOLD IMPROVEMENT MANUAL .....	24
3.6 ASBESTOS RELATED WORK .....	24
3.6.1 Notification .....	25
3.6.2 Conditions for Work which may Disturb Asbestos Containing Materials .....	25
3.6.3 Duct Modification Procedures in Commerce Court West .....	25
3.6.4 Working around Asbestos Containing Joint Compound .....	26
3.6.5 Replacing Fireproofing .....	26
3.6.6 Clean-Up, Removal and Disposal .....	26
3.6.7 Completion of Work .....	27
3.6.8 Discovery of Friable Material .....	27
3.6.9 Failure to Comply.....	27
3.6.10 Occupational Health & Safety Act Asbestos Regulation .....	27
3.7 CARPET LAYING .....	28
3.8 CEILING GRID.....	28
3.9 CLEARANCE REQUIREMENTS FOR INSULATED GLASS UNITS .....	28
3.10 COMMENCEMENT OF TENANT’S IMPROVEMENTS.....	28
3.10.1 Inspection of Tenant Premises .....	28
3.10.2 Inspection of Tenant’s Work in Progress.....	29
3.11 COMPLETION OF WORK (also refer to section 2.5) .....	29
3.12 CONTROLS.....	30



3.13 CONSTRUCTION NOISE .....	30
3.14 COURTYARD PAVER PROTECTIONPOLICY.....	30
3.15 DAILY CLEAN-UP .....	31
3.16 DAMAGE .....	31
3.17 DRILLING, CUTTING WORK AND X-RAYS.....	31
3.17.1 Proposed Drilling or Coring Locations.....	32
3.17.2 X-Raying .....	32
3.17.3 Drilling and/or Coring .....	32
3.18 DUCT MODIFICATION PROCEDURES IN COMMERCE COURT WEST .....	33
3.19 EMERGENCY CONTACT .....	33
3.20 EMERGENCY PROCEDURES FOR CONTRACTORS.....	34
3.20.1 No Smoking.....	34
3.20.2 Fire Prevention .....	34
3.20.3 Fire Safety Emergency Procedures.....	34
3.20.4 Exits .....	35
3.20.5 Floods/Water Leaks.....	35
3.20.6Medical Emergencies or Accidents.....	35
3.21 FASTENINGS .....	35
3.22 FEES PAYABLE BY TENANT .....	36
3.23 FIRE SAFETY SYSTEMS .....	36
3.23.1 Pull Stations .....	36
3.23.2 Relocating Fire Hose Cabinets.....	36
3.23.3 Sprinkler and Standpipe Drain Downs.....	36
3.23.4 Testing and Maintenance (Pull Station and Magnetic Locks).....	39
3.24 GARBAGE.....	40
3.25 LIENS .....	41
3.26 LOADING DOCK .....	41
3.27 MECHANICAL, ELECTRICAL, AND COMMUNICATION ROOMS .....	41
3.27.1 Riser Room Access for Main Telephone Room (MTR), Riser Rooms, and Rooftop .....	42
3.27.2 On-Site Review Audit.....	42
3.27.3 Standards of Work (refer to APPENDIX I).....	42
3.27.4 Return to Base Building Cable Abatement Management & Control (refer to Appendix I).....	43



3.27.5 Fee Schedule for Site Review .....	43
3.28 PAINTING .....	44
3.29 PARKING .....	44
3.30 PLUMBING AND METERING .....	44
3.30.1 Specification for BTU meter .....	44
3.31 PROTECTION OF UNITS BEFORE CONSTRUCTION COMMENCEMENT .....	45
3.32 PUBLIC SAFETY- CONTRACTOR COMPLIANCE .....	45
3.33 SECURITY CONTROL- CONTRACTOR ACCESS .....	46
3.34 SECURITY ESCORTS .....	46
3.35 SECURITY OF LEASED PREMISES .....	46
3.36 SERVICE ELEVATOR .....	46
3.36.1 Service Elevator Load Capacity .....	47
3.36.2 Service Elevator Dimensions .....	47
3.37 SITE MEETINGS .....	48
3.38 SPECIAL LANDLORD'S CHARGES .....	48
3.39 SPRINKLER SYSTEM .....	48
3.39.1 Sprinkler Drain Down .....	49
3.39.2 Standpipe (fire hose cabinet) Drain Down .....	49
3.40 STAIRS AND ACCESS AREAS .....	49
3.41 STATUTORY DECLARATION FORM .....	49
3.42 STORAGE AND DISPOSAL OF HAZARDOUS WASTE MATERIAL .....	50
3.43 TEMPORARY SERVICES .....	50
3.43.1 Power .....	50
3.43.2 Telephone .....	50
3.44 TENANT CONTRACTOR(S) REQUIREMENTS .....	50
3.44.1 City Permits .....	50
3.44.2 Approved Drawings .....	51
3.44.3 Construction Schedule (refer to section 2.5) .....	51
3.44.4 Existing Finishes .....	51
3.46 TIE-INS .....	51
3.47 WATER SYSTEM SHUTDOWNS .....	52
3.48 WELDING AND ANY OPEN FLAMEWORK .....	52

3.49 WORK PERMITS .....	53
3.50 WORKING AREAS.....	53
3.51 WORKING HOURS.....	53
SECTION 4 - BASE BUILDING FINISHES & STANDARDS.....	54
4.1 BASE BUILDING FINISHES AND STANDARDS.....	54
4.1.2 Washrooms.....	55
4.1.3 Furniture Layout .....	57
4.1.4 Painting .....	57
4.1.5 Curtain Walls .....	58
4.1.6 Hardware.....	58
4.1.7 Window Coverings .....	59
4.1.8 Signs (refer to section 3.45) .....	59
4.1.9 Marble Tile (Concourse Level).....	60
4.1.10 Common Corridor .....	60
SECTION 5 - BASE BUILDING SYSTEMS.....	62
5.1 MECHANICAL SYSTEMS.....	62
5.1.1 General Heating, Ventilating and Air Conditioning Systems (HVAC).....	62
5.1.2 Commerce Court Piping Identification and Valve Tagging.....	62
5.1.3 Commerce Court West (CCW) 199 Bay Street & Commerce Court East (CCE) 21 Melinda Street.....	62
5.1.4 Commerce Court North (CCN), 25 King Street West .....	63
5.2 ELECTRICAL SYSTEMS.....	64
5.2.1 General Conditions for Commerce Court Complex.....	64
5.2.2 Tenant Sub Metering System .....	64
5.2.3 Tenant Improvement/Renovation will include: .....	65
5.2.4 Tenant's Electrical Contractor: Specifications for Meter Changes/Additions .....	65
5.2.5 Electrical Lockout/Tag Out: .....	66
5.2.6 Power Shutoff and Lockout of Equipment .....	66
5.2.7 Return of Equipment to Service .....	67
5.2.8 Transformers.....	68
5.2.9 Wire .....	68
5.2.10 Identification.....	68



5.2.11 Fastenings.....	69
5.2.12 Lighting .....	69
5.2.13 Base Building Lighting .....	69
5.2.14 Communications Cabling .....	69
5.2.15 Lighting Specifications .....	70
5.3 STRUCTURAL SYSTEMS .....	72
5.4 ELECTRONIC SECURITY MANAGEMENT SYSTEMS(SMS) .....	73
5.4.1 Work Permits .....	74
5.4.2 SMS Technical Standards Document .....	75
SECTION 6 - RETAIL GENERAL CRITERIA.....	77
6.1 RETAIL ARCHITECTURAL.....	77
6.2 RETAIL MECHANICAL SYSTEM.....	77
6.3 RETAIL HEATING, VENTILATION AND AIR CONDITIONING.....	78
6.4 RETAIL EXHAUST .....	78
6.5 RETAIL GAS .....	79
6.6 RETAIL PLUMBING.....	79
6.7 RETAIL SPRINKLER SYSTEM .....	79
6.8 RETAIL ELECTRICAL .....	79
SECTION 7 - STORE FRONT CRITERIA .....	81
7.1 EXTERIOR STORE FRONTS.....	81
7.2 RETAIL STOREFRONT .....	81
7.3 RETAIL DESIGN CONTROL AREAS.....	82
7.4 COMMERCE COURT NORTH STORE FRONT .....	82
7.5 COMMERCE COURT NORTH STORE FRONT DESIGN CRITERIA .....	83
SECTION 8 - RETAIL SIGNAGE CRITERIA .....	85
8.0 RETAIL SIGNAGE CRITERIA.....	85
8.1.1 - Signage Criteria.....	85
8.1.2 - Industry Sign Standards.....	85
8.1.3 - Food Court Specific Signage .....	85

## SECTION 1.0 - INTRODUCTION

The Commerce Court Leasehold Improvement Manual has been prepared to assist Tenants in the design and construction of leasehold improvements. However small or limited in scope, every project must be fully examined and approved by the Landlord before any implementation is permitted or undertaken.

This manual outlines the basic design specifications for the building. The information provided here applies generally and should be made available by the Tenant to their designers, consultants, and contractors, who should acquaint themselves thoroughly with the material herein, as it will form the basis of the Landlord's approval of all Tenant submissions.

The Landlord's approval of all drawings is for the purpose of obtaining information about the intended design, use of the premises and the impact the design may have on the base building systems, structurally, electrically, or mechanically.

The Landlord will not confirm your consultant's design accuracy; review is only to approve or disapprove of the impact on the base building systems.

The Tenant and/or designer should visit the site to inspect and verify all site conditions prior to the commencement of design work.

The Landlord reserves the right to amend or add to the information in this manual at any time and the Tenant is obliged to abide by such changes. All costs associated with the compliance shall be at the Tenant's expense. The most current edition of this manual is available on the [Commerce Court Website](#).

This manual is intended to reflect only standard conditions or situations and does not amend the formal Lease agreement which is to govern in the event of any inconsistencies.

**Permission to deviate from the criteria contained herein must be obtained in writing. Notes on drawings in conflict with the design criteria have no validity.**





### 1.1 CONSTRUCTION SERVICES

The primary function of Construction Services, as the Landlord’s representative, is:

- To provide guidance and assistance to Tenants during both the design and construction phases of their Leasehold improvements;
- To protect the integrity of the asset on behalf of the Landlord and the Tenants;
- To review and comment upon all Tenant submissions before work begins with the Leased premises;
- To ensure all construction aspects of the Tenant’s Lease are maintained at all times;
- To provide liaison between and among the Landlord, Landlord’s Contractor and Consultants, the Tenant’s Contractor and Designer;
- To pursue all environmental considerations.

### 1.2 PROPERTY MANAGEMENT CONTACTS

**COMMERCE COURT EMERGENCY TELEPHONE NUMBER: 416.364.2050**

**bcIMC Realty Corporation c/o QuadReal Property Group  
Commerce Court Property Management Office  
199 Bay Street, Suite 1910  
Toronto, Ontario M5L 1E2**

---

**Main Reception** T | 416.364.2281

---

**Security and Life Safety Services (24 Hrs)** T | 416.364.6366

The Security Shift Supervisor is the **primary after-hours** contact for any property damage, safety or security related occurrence.

---

**June Jack** T | 416.364.1267  
Manager, Building Services E | [ccto-buildingservices@quadreal.com](mailto:ccto-buildingservices@quadreal.com)

June is the primary contact for any day-to-day loading dock related business and he is responsible for the booking of freight/service elevators for Commerce Court.

---

**Steven Bowers** T | 416.361.4507  
Manager, Operations E | [steve.bowers@quadreal.com](mailto:steve.bowers@quadreal.com)



---

**Cathy Branco**

Manager, Resident Janitorial &amp; Housekeeping

T | 416.364.2757

E | [commerce@hallmarkkeeping.com](mailto:commerce@hallmarkkeeping.com)

---

**Andrew D’Cruz**

Locksmith, Base Building

T | 416.364.3478

E | [Andrew.dacruz@quadreal.com](mailto:Andrew.dacruz@quadreal.com)

**Any requirement to contact one of the above personnel after normal business hours should be made by calling the Building Control Centre at 416.364.8025**

### 1.3 LANDLORD APPROVED CONSULTANTS

**\* Bolded denotes base building consultant**

#### Architect

Zeidler Partnership

Valerie Banelis

[vbanelis@zeidlerpartnership.com](mailto:vbanelis@zeidlerpartnership.com)

Queenie Wong

[qwong@zeidler.com](mailto:qwong@zeidler.com)

#### Structural

**\*EXP (formerly Trow)**

Roy Flood

T| 905-695-3217 #3724

[roy.flood@exp.com](mailto:roy.flood@exp.com)

WSP Canada Inc.

John P. Kosednar

T| 416-568-4576

[john.kosednar@wsp.com](mailto:john.kosednar@wsp.com)

Stephenson Engineering

Mohsen Mansouri

T| 416-635-9970 #222

[mmansouri@stephenson-eng.com](mailto:mmansouri@stephenson-eng.com)

Morrison Hershfield Limited

Jeremy Carkner

T| 289-266-1901

[jcarkner@morrisonhershfield.com](mailto:jcarkner@morrisonhershfield.com)

#### Mechanical and Electrical

**\*TMP****BB Mechanical CCN**

Dermot Barry

T| 416-499-8000

[dbarry@tmptoronto.com](mailto:dbarry@tmptoronto.com)



**\*Mulvey & Banani  
BB Electrical CCN**

Joe Berardi

T| 416-751-2520  
[jberardi@mbii.com](mailto:jberardi@mbii.com)

**\*Smith and Andersen  
BB Mechanical CCW, CCE  
and CCS**

Tony Spina

T| 416-218-7036  
[tony.spina@smithandandersen.com](mailto:tony.spina@smithandandersen.com)

**\*Smith and Andersen  
BB Electrical CCW, CCE  
and CCS**

John Pascoa

T| 416-218-7007  
[john.pascoa@smithandandersen.com](mailto:john.pascoa@smithandandersen.com)

Morrison Hershfield  
(Electrical)

Tital Gurau

T| 416-495-4287  
[tgurau@morrisionhershfield.com](mailto:tgurau@morrisionhershfield.com)

**Asbestos and Environmental  
\*Pinchin Ltd.**

[quadrealgta@pinchin.com](mailto:quadrealgta@pinchin.com)

**Security Systems**

**\*Lattice Engineering  
Inc.**

Bill Todorov

T| 416-219-9421  
[bill.todorov@rogers.com](mailto:bill.todorov@rogers.com)

**Life Safety & Suppression System**

**\*Nadine International**

Ajwad Gebara

T| 905-602-1850  
[ag@nadineintl.on.ca](mailto:ag@nadineintl.on.ca)

**Communications/Riser Management**

**\*Rycom Building  
Connections**

Customer Care

T| 1-877-792-6687  
[customer@rycom.ca](mailto:customer@rycom.ca)

**Commissioning Services**

**\*CDML Commissioning  
Services**

Mark Boswell

T| 416-723-8537  
[mboswell@cdml.ca](mailto:mboswell@cdml.ca)

GCMY Incorporated

Gavin Yeung

T| 416-899-4994  
[gavin.yeung@gcmy.ca](mailto:gavin.yeung@gcmy.ca)

\*\*any work performed on a tenant security system must conform to the SMS Technical Standards Document and must be approved/commissioned by the Base Building Security System Integrator, at



the tenant's expense. The SMS Technical Standards Documents can be requested through Tenant Services at [cctoservices@quadreal.com](mailto:cctoservices@quadreal.com). Please refer to section 5.4.4 for more information.

#### 1.4 REGULATORY BODIES

The Tenant is required to design and construct its improvements in accordance with all the applicable codes, by-laws and the directives of all governing authorities. The Tenant is also required to secure its own building permit and all other approvals required by law.

Urban Development Services City Hall -  
1st Floor, West Tower 100 Queen Street West  
Toronto, Ontario, M5N 2N2

#### 1.5 LANDLORD APPROVED CONTRACTORS

##### Electrical

Black & McDonald	Finlay McCallum	647-223-6664 <a href="mailto:fmcillum@blackandmcdonald.com">fmcillum@blackandmcdonald.com</a>
CMS Electrical	Gareth Fellows	416-892-8071 <a href="mailto:gareth@cmselectricalgroup.com">gareth@cmselectricalgroup.com</a>
Guild Electric	Mark Donner	416-688-1597 <a href="mailto:Mark.donner@guldelectric.com">Mark.donner@guldelectric.com</a>
Intell Lighting Inc.	Mark Osborne	647-295-6579 <a href="mailto:m.osborne@intelllighting.com">m.osborne@intelllighting.com</a>
Plan Group	Syd Oliveira	416-522-5930 <a href="mailto:soliveira@plan-group.com">soliveira@plan-group.com</a>
Smith and Long Ltd.	Michael Forty	416-391-0443 <a href="mailto:mforty@smithandlong.com">mforty@smithandlong.com</a>
Symtech Innovations	Brent Stewart	647-327-6216 <a href="mailto:brent.stewart@symtech.com">brent.stewart@symtech.com</a>

##### Mechanical

Black & McDonald	Finlay McCallum	416-991-5070 <a href="mailto:fmcillum@blackandmcdonald.com">fmcillum@blackandmcdonald.com</a>
------------------	-----------------	--



Commercial  
Mechanical Services

Clive Lacey

905-219-0008  
[clive@cmsmech.com](mailto:clive@cmsmech.com)

Impact Mechanical  
Services

William Smith

416-609-9992 #31  
[bsmith@impacteml.com](mailto:bsmith@impacteml.com)

Modern Niagara  
Toronto Downtown

Tim Theodosiu

416-360-1617  
[torontodowntown@modernniagara.com](mailto:torontodowntown@modernniagara.com)

OPUS Mechanical  
Services

Blair McDonnell

416-312-4500  
[blair@opusmechanical.com](mailto:blair@opusmechanical.com)

Plan Group

Syd Oliveira

416-522-5930  
[soliveira@plan-group.com](mailto:soliveira@plan-group.com)

### Mechanical (Controls)

MTI Ltd.

Larry Sobotka

905-513-1953

### Air Balance Testing

Ace Commercial

Ajay Jhajj

416-727-2009  
[info@aceairbalancing.com](mailto:info@aceairbalancing.com)

### Security Systems (Access Control Readers, CCTV And Alarms)

Securitas Electronic  
Security Canada

Brian Keller

647-407-0060  
[Brian.keller@securitates.com](mailto:Brian.keller@securitates.com)

*(Securitas must be used for integration into base-building systems)*

TAK Technologies  
Ltd.

Chris Addool

905-212-1200 #3  
[chris.a@taktechnologies.ca](mailto:chris.a@taktechnologies.ca)

### Fire Alarms

Siemens

Ryan Brockway

416-388-7672  
[ryan.brockway@siemens.com](mailto:ryan.brockway@siemens.com)



## Sprinklers

Classic Fire  
Protection, Inc.

Steve Peckham

416-740-3000  
[peckham@classicfire.com](mailto:peckham@classicfire.com)

General Sprinkler  
Ltd.

Frank Ciotola

416-748-1175 #223  
[Frank.c@gsinc.ca](mailto:Frank.c@gsinc.ca)

Onyx Fire

Marty Schell

416-674-5633  
[mschell@onyx-sprinkler.com](mailto:mschell@onyx-sprinkler.com)

Vipond Fire  
Protection

Danielle Pearson

905-564-7060 #229  
[Danielle.pearson@vipond.ca](mailto:Danielle.pearson@vipond.ca)

## Locksmith

QuadReal Property  
Group

Andrew D'Cruz

416-364-3478  
[Andrew.dacruz@quadreal.com](mailto:Andrew.dacruz@quadreal.com)

## Asbestos Removal

Alliance  
Environmental

Laurie Thornton

416-298-4500  
[info@allianceenvironmental.com](mailto:info@allianceenvironmental.com)

The Bear Star Group

Rob Boyko

647-427-4466  
[rob@bearstargroup.com](mailto:rob@bearstargroup.com)

Biggs & Narciso

Luis Narciso

905-470-8788 #5463  
[luis@biggsandnarciso.com](mailto:luis@biggsandnarciso.com)

FirstonSite  
Restoration

Kevin Spiers

416-272-5919  
[kpiers@firstonsite.ca](mailto:kpiers@firstonsite.ca)

I & I Construction

John Watters

905-884-1290 #204  
[jwatters@iandi.ca](mailto:jwatters@iandi.ca)



Communications /Riser Management  
Rycom Building      Customer Care  
Connections

1-877-792-6687  
[customercare@rycom.ca](mailto:customercare@rycom.ca)

# SECTION 2.0 – TENANT DESIGN, WORKING DRAWINGS & WORK ADMINISTRATION PROCESS

## 2.1 SUSTAINABLE TENANT DESIGN

- **Hire Interior Designers, Engineers, and Contractors** that are knowledgeable about sustainable design and construction practices. One good place to start is the Canada Green Building Council's website where they have a directory of accredited professional experts in sustainable design/construction ([www.cagbc.org](http://www.cagbc.org)).
- **Install low VOC (Volatile Organic Compounds) materials.** Make environmentally conscious choices when selecting carpets, adhesives, paints, finishes, sealant and composite wood products.
- **Incorporate sunlight and access to views in the design** of the space so that all your employees reap the benefits. Daylighting or allowing abundant natural light indoors, enhances interior light quality and reduces energy demands. The use of glass in sustainable- design office space should be selected with consideration given to visible light transmittance, heat loss and gain, ultraviolet ray transmittance, and color. The use of high-performance glazing systems in the design of interior or private office placement admits more light while simultaneously rejecting a higher percentage of solar heat gain, resulting in better lighting during the day and reduced cooling loads.
- **Insist that contractors recycle** as much construction waste as possible. Did you know that contractors can recycle concrete, metal, glass, wood drywall, plastics and even packaging waste? Demolition and construction waste accounts for over 30% of total waste sent to landfills. Recycling construction waste can also be less expensive than sending waste to the land fill as tipping charges are much lower at recycling depots than landfills.
- **Install materials with high recycled content.** Building construction accounts for over 40% of raw materials used globally. By using materials with a high recycled content, you are reducing the need for raw material extraction and reducing the amount of waste that ends up in a landfill. Again, materials with a high recycled content are becoming readily available at little or no additional cost.
- **Take stock of what you already have.** Is there something in your existing space that could be reused or adapted to your new space?
- **Save energy! Put occupancy sensors and/or light switches** in rooms that isn't constantly used (kitchens, supply rooms, meeting rooms) so the lights automatically shut off when staff aren't around. Minimize or eliminate



specialty lighting. Advances in a lamp, ballast, and fixture technology produce more light with less energy. Good lighting design uses as little as 0.5 to 0.75 1P watts per sq. ft. of floor space, compared to lighting loads of 2.5 to 3 watts in traditional office design. Furthermore, sensors that measure indoor light levels can raise and lower artificial lighting in response to changing outdoor conditions, and occupancy sensors turn lights off when not needed.

- **Ventilation systems:** Tenant design should take into consideration improved ventilation with well- designed mechanical and electrical systems to deliver air-flow effectiveness, provide plentiful fresh air, and reduce exposure to bio-contaminants such as microbial diseases, fungi, and molds. High-efficiency filtration systems are very effective in reducing air quality. Improved ventilation also removes indoor pollutants generated by the off gassing of materials such as carpet, adhesives, sealants, furniture coverings, and paints and varnishes, as well as reduces carbon dioxide levels.
- **Reduce water use:** Many cost-effective options can reduce water use by up to 30 percent. Toilets now use 1.6 gallons per flush versus 3 to 5 gallons per flush on older models. Sensor- operated faucets and urinals help save water and improve sanitary conditions.
- **Materials Selection:** Building and finish materials should be selected with regards to renewability, recycled content, manufacturing processes, packaging, and shipping (i.e., using materials that are locally manufactured or harvested). Sustainable design practices also incorporate less-toxic premises materials and furnishings. Carpets and floors, paints, varnishes, furniture, and other materials should be carefully and researched prior to specification. Life-cycle cost analyses of materials should also be conducted to compare not only a system or material's first cost but also to consider its cost over the building's entire life span. An increase in the manufacturing of such products has reduced their costs while increasing selection and quality.

### 2.1.1 Sustainable Tenant Design: The Bottom Line

Sustainable design does not come from employing piecemeal changes that create minor reductions in resource use and total life-cycle costs. Tenants can benefit the most from the sustainable design if they work with qualified designers, construction managers, and building management to take a holistic approach to planning, designing, and construction of their space. Simultaneously considering design, construction, and interlinked issues, such the building electrical/mechanical and lighting systems optimize all aspects of a project. In the end, an integrated approach often creates multiple benefits for both the building owner and the tenant.

### 2.3 TENANT CONSULTANTS AND FEES

The Tenant shall engage all the Architects, Designers, and Engineers to prepare dimensioned drawings and specifications for the construction of the Tenant's Leasehold improvements.

The Tenant is encouraged to use the Landlord's base building mechanical, electrical, and structural consultants if practical (refer to section 1.3). The Landlord will engage the base building consultants for all drawing reviews and, if the Tenant engages a different firm, the cost of the Landlord's review will be at the Tenant's expense.

The Landlord, from time to time, may require the Tenant to produce additional or more detailed drawings or information which in the Landlord's opinion may be necessary to identify and describe the nature of the intended improvements.

The Tenant shall inform themselves of any by-law and code requirements as well as this Leasehold Improvement Manual, before preparing the plans and specifications.

By giving approval to such plans, the Landlord does not waive the Tenant's responsibility to ensure that all Tenant improvements meet the requirements of the Lease, this Leasehold Improvement Manual or the latest Ontario Building Code. Further, any construction deficiencies, HVAC, air flow problems, etc., are the responsibility of the Tenant and their respective Contractor. The Landlord's review of the drawings is only to ensure that the Tenant's design does not impede with the building's system or aesthetics.

### 2.4 APPROVAL OF TENANT DRAWINGS

#### 2.4.1 Submission of Preliminary Drawings

The Tenant shall submit via email one (1) 11x17 PDF of the preliminary floor plan, identifying partition wall locations. The preliminary drawings will be checked from the standpoint of physical compatibility and any problems encountered shall be returned to the Tenant for resolution. If required, the Tenant shall revise the preliminary drawings and resubmit them showing the proposed resolution of the Landlord's concerns for approval prior to the commencement of work.

#### 2.4.2 Submission of Final Plans and Specifications

The Tenant shall submit one (1) electronic copy (CAD and PDF) and one (1) set of complete working, "D" size (24 x 36 inches), "Issued for Tender" construction drawings and specifications for final approval by the Landlord, which will be given within ten (10) business days of receipt of the submitted drawings in accordance with the Construction Procedures contained in the Lease and prior to the commencement of the fixturing period. Electrical, mechanical and structural drawings must be signed and sealed by the engineer responsible for the design. Any drawings not completed by the base building engineer will be sent to the base

building engineer for review. Any associated costs associated will be charged to the tenant.

**Tenant drawings must be sized 24 x 36 inches and shall be drawing scale (1/8" = 1'-0") minimum and consist of the following:**

- **Floor Plans:**
  - The locations of all major fixed elements within the Leased premises dimensionally related to grid lines and demising partitions.
  - Room names and uses.
  - The locations and layouts of rooms with unusual loading concentrations (for example, centralized filing areas, libraries)
  - Materials and finishes throughout the premises.
  - The number of people to occupy the suite including all heat load calculations for the determination of HVAC requirements.

*Where the Leased premises occupy less than a full floor, plans must include the entire floor showing the location of the Leased premises and their relationship to the elevator lobby, exits, washrooms, etc. (A key plan must be submitted.)*

- **Telephone, Data, and Power Outlet Plan:** indicate dimensions and location of all telephone, data and power outlets.
- **Reflected Ceiling/Lighting Plans:**
  - Lighting, motion sensor lighting zones, layout, ceiling pattern, air transfer ducts, materials and suspension-system details
  - The locations of any sound baffles above the ceiling
  - The locations of any access panel required to service building systems.
  - The locations of any air transfer ducts and baffles through full height partition and/or baffles from ceiling to underside of the slab
- **Sections and Details:** Should be at a suitable scale to indicate partition details, baffles, doors, etc.
- **Room Finish, Door, and Hardware Schedule:** Two copies of the hardware schedule must be submitted to indicate all elements including keying which must be to building standard as per Section 4 Hardware. Hardware must be approved by the Landlord.
- **Complete Mechanical, Electrical, Sprinkler, Building Automation and Life- Safety System Drawings:** showing all work that is an alteration/addition to the base building system and all parts of the base building system that remain unchanged. Tie-ins and extensions to base building security, fire alarm, and communication systems must also be clearly shown.
- **Structural Drawings:** Must be supplied only when modifications to the structure are anticipated. These drawings are to be created by the base building Structural Engineer. Should the Tenant opt to use their own

Structural Engineer, the Landlord will forward said plans to the base building Engineer for review at the Tenant's sole expense.

#### 2.4.3 Drawing Revisions

Upon completing its review, the Landlord shall return any marked drawings along with all comments and required corrections set out by the Landlord and that of the base building consultants. The Tenant shall revise their drawings to include all the comments and corrections and provide the Landlord with a revised half size set of prints. **Unapproved drawings shall be revised by the Tenant to conform to the Landlord's requirements and resubmitted to the Landlord for approval.** The Landlord shall not be obligated to change or extend any of the dates contained in the Lease if the drawings are rejected by the Landlord or its consultants.

#### 2.4.4 Specifications

**One (1) electronic copy and one (1) set of specifications** must be submitted with the final set of working drawings describing the quality and performance standards for all Tenant work.

#### 2.4.5 Drawing Review

The drawing review does not imply that the plans and specifications comply with applicable governmental requirements nor that they are satisfactory having regards to professional architectural, engineering or similar standards. Review and approval do not in any way impose upon or imply acceptance of responsibility on the part of the undersigned with respect to all or any part of the approved plans and specifications. Approval is given for the limited purpose of allowing construction and installation to proceed subject, in each case, to the continuing responsibility and liability of the person or entity that submitted them for compliance with all applicable governmental requirements, building standards and the applicable requirements and standards for design and construction.

The drawing review letter is required to be reviewed by the tenant and applicable project managers, general contractors, contractors etc. in its entirety signed and returned to Construction Services prior to project commencement.

#### 2.4.6 Permits

The Tenant is responsible for obtaining all necessary permits and approvals from the Building Department, Health Department, Toronto Fire Services, the Ministry of Labour and any other governing authority having jurisdiction. **The Tenant shall submit copies of the building permit** and any other required permits or approvals to the Landlord prior to the commencement of the Tenant's construction, refer to section 2.5.

#### 2.4.7 Contactors

The Tenant shall engage, at the Tenant's expense, **the Landlord's pre-approved Contractors** for all required mechanical, electrical, sprinkler, access control,

controls, asbestos abatement and balancing modifications or additions to the base building systems.

## 2.5 WORK ADMINISTRATION PROCESS

### 2.5.1 Documents Required Prior to Work Permit Approval and Commencement of Work

1. One (1) electronic copy (CAD and PDF) and one (1) set of “D” size (24 x 36 inches) construction drawings and documents to be approved by the Landlord (refer to section 2.4 for drawing specifications).

**Note: as outlined in Section 2.4, the Landlord has ten (10) business days to review the drawings and provide feedback to the tenant. Please consider this when coordinating the project schedule.**

2. A signed copy of the Landlord’s drawing review letter.
3. The arrangement of a start-up meeting with the Contractor to review the rules and regulations of Commerce Court and to assist in any questions they may have regarding the building. A QuadReal staff member of the Construction Services team must be present during the start-up meeting/walk-through.
4. Contractor’s Certificate of Clearance from the (WSIB) Workplace Safety and Insurance Board (current).
5. A copy of the City Building Permit Application and all permits issued by the jurisdictions having authority. A copy of all City Permits must be posted at the job site. *Note: In accordance with Ontario Regulation 305/03 (Bill 124) no construction will commence without a Building Permit.*
6. A copy of the Notice of Project provided to the Ministry of Labour prior to starting projects that meet the standards set out in section 6(1) of the regulation for *Construction Projects, O. Reg 213/91 under Occupational Health and Safety Act, RSO. 1990. C. O. 1*
7. Contractor’s Certificate of Insurance is to be obtained and maintained, which shall insure the Owner (bcIMC Realty Corporation), the Manager (QuadReal Property Group Limited Partnership and QuadReal Property Group G.P. Inc. and their successors and assigns) and the Contractor against all claims, liabilities, and legal fees relating to the Contractor carrying out the work:
  - a) Commercial general liability in the sum of at least \$5,000,000 (five million dollars) on an occurrence basis including:
    - i. Bodily injury
    - ii. Property damage
    - iii. Completed operations
    - iv. Non-owned automobile
    - v. Employer’s liability (if applicable)
    - vi. Cross liability/severability of interest clause

- vii. The Owner and Manager shall be named as additional insured but only with regards to the operations of the named insured.

Limit for commercial general liability may be made up of a combination of primary and umbrella liability policies.

- b) If applicable, automobile liability in the sum of at least \$2,000,000 (two million dollars)
8. A project contact list including Client, General and Subcontractors, with emergency contact names, telephone numbers and emails.
9. A detailed construction schedule.
10. Rycom Pre-Construction Inspection Report (section 3.27 and APPENDIX I)
11. Pinchin Ltd.'s Designated Substance Report (D-Sub)
12. Pinchin Ltd.'s Design & Specifications Report
13. The General Contractor must sign and submit the "Contractor's Asbestos Notification and Acknowledgement" form (Section 3.6.1 & APPENDIX II)
14. For work in areas with known asbestos, the General Contractor must sign and submit the "Form 3". This can be obtained from Property Management. A copy of the "Form 3" must be posted at the job site.

\*Note: Upon receipt of the above applicable documents, work permit requests will be approved. Please refer to section 3.49 for additional information

### 2.5.2 Documents Required during Work

- Copies of all site meeting minutes
- Copies of all Contemplated Changes and/or Change Orders at time of issuance to Contractors
- Copies of all Architect, Consultant, or Designer site visit reports
- Copies of all site reports from authorities having jurisdiction
- A copy of the MSDS sheet for all materials used during renovation including but not limited to adhesives, paint, caulking etc.
- The Landlord requires at least **five (5) business days'** notice prior to commencing asbestos related work (section 3.6.2). The Landlord should also be informed when asbestos related work has been completed.

\*Note: Working hours are Monday to Friday, 7:00 AM - 6:00 PM. During this time, noisy or disruptive work is not authorized (section 3.51).

### 2.5.3 Documents Required Following the Completion of Work (also refer to Section 3.11)

- One (1) complete hard copy set of Consultant approved "As-Built" Drawings, "D" sized (24" x 36") and one (1) electronic copy of CAD/PDF files.

Please Note: A complete set of these drawings will be uploaded onto the management software at a cost to the Tenant of \$5.00 per plan. Rate may change without notice.

- Substantial completion letter from professional on project.
- Statutory declaration from holdback release
- Letter from all Tenant designers, professional consultants and jurisdictions stating that the project has been completed in accordance with the contract drawings and specifications.
- Air Balancing Report to be submitted with engineer's stamp and signature verifying that final balance report meets design criteria.
- A Certificate of Inspection from the Electrical Safety Authority.
- NFPA Letter and Fire Alarm System Verification Report.
- Rycom Pre-Inspection Report if not previously submitted (section 3.27 and APPENDIX I)
- Rycom Post-Construction Inspection Report (section 3.27 and APPENDIX I).
- Hazardous material disposal forms (section 3.6).
- Pinchin Ltd.'s site inspection reports.
- Operating manuals and maintenance procedures.
- Warranty letters related to all equipment, materials, finishes and labour.
- Final written inspection report approved by the City Inspector (noting all permit numbers and dates permits were closed)
- Confirmation from the Tenant that all surplus base building equipment or materials that are to remain the property of the Landlord have been delivered to the Landlord in good working order
- Third party commissioning report for all HVAC and associated work
- Third party commissioning report for lighting and associated work

**Close out documents must be received by the Landlord no later than forty-five (45) days after the completion of work.** Note: not all close-out documents will be applicable to every project.

## SECTION 3.0 – PROCEDURES & REGULATIONS

### 3.1 ABOVE CEILINGWORK

All above ceiling work carried out in areas where asbestos is present will require Landlord approval. All related work must be reviewed by Pinchin, the base building Environmental Consultant, to establish the regulations in which the work is to be carried out. Inspection of all above ceiling work will require **seven (7) days'** notice and completed by Construction Services and Technical Services.

### 3.2 ACCESS PANELS

Access panels in wall, ceiling and floor construction must be provided by the Tenant at its own expense and/or as directed by the Landlord to permit necessary access to equipment or services. The Contractor is to coordinate on site the location, type, size and a number of panels, etc., by calling the Tenant Services Hotline at (416) 364-4110.

### 3.3 AIR BALANCE REPORT

The Tenant must engage through the Landlord, **the Landlord's air balance Contractor** to provide an air balance report upon completion of all Leasehold improvement work, including all expansions and new renovations. The report must be done at the Tenant's expense and must be reviewed by the Landlord's consultant. Stamped and Signed.

### 3.4 AIR INTAKE (BREATHER)

Any window removal and air intake installation, and removal of same/reinstallation of a window, will be coordinated by Construction Services. All associated costs will be at the Tenant's expense. A minimum of **five (5) business days** written notice is required. This work is to be performed after-hours, weather permitting.

Unauthorized Contractors attempting to remove or reinstall a window will be subject to the maximum fines identified in this manual plus any associated costs to remedy the resulting situation (APPENDIXII).

### 3.5 AMENDMENTS TO LEASEHOLD IMPROVEMENT MANUAL

The foregoing information, procedures, and regulations may be amended from time to time by the Landlord. The current edition of this manual is available on the [Commerce Court Website](#).

### 3.6 ASBESTOS RELATED WORK

**Asbestos containing materials (ACM) are present throughout our towers and sub-levels.**

During the construction of the West Tower of the Commerce Court Complex, sprayed fireproofing containing chrysotile asbestos was applied to structural steel, including metal decking and behind perimeter induction units on exterior curtain walls. Since construction was completed, asbestos- containing sprayed fireproofing has been removed from numerous areas of the building. Copies of technical reports regarding sprayed fireproofing may be viewed in the office of Commerce Court Property Management.

Other friable and non-friable asbestos-containing materials are present in the four towers of the Commerce Court Complex. These materials are identified in the Commerce Court Asbestos Building Materials Survey prepared by Pinchin Ltd.



**All projects must be assessed for the possibility of disturbing asbestos containing materials PRIOR to the commencement of work. All work which may disturb ACM must be coordinated through Commerce Court Property Management.**

### 3.6.1 Notification

Work which may disturb ACM must be arranged with Property Management at least **five (5) business** days in advance. As per section 2.5.1, a copy of Pinchin Ltd.'s Designated Substance Report and Design & Specifications Report must be submitted to Construction Services prior to the commencement of asbestos-related work. A Form 3 (APPENDIX III) will be provided to the General Contractor to acknowledge the presence of asbestos and confirm that they have notified all their sub- contractors. This form is to be completed and returned to Construction Services (refer to section 2.5.1). **A signed copy of Form 3 must be posted on the job site at all times, along with the building permits.**

### 3.6.2 Conditions for Work which may Disturb Asbestos Containing Materials

Work which may disturb ACM is only permitted in Leased and/or occupied areas during non- business hours, e.g., after 11:00 PM and before 7:00 AM, or on weekends. Absolutely no penetrations or openings can be affected into a known area containing asbestos when there are any other occupants in the vicinity of the work. The ventilation system must be disabled, and air return vents sealed prior to penetrating or opening an area containing ACM.

### 3.6.3 Duct Modification Procedures in Commerce Court West

Duct modification work includes the removal of diffusers or VAV boxes, relocating diffusers from one location to another, cleaning dust/debris within the ducts and cutting existing ducts to accommodate the installation of new flex or branch ducting. In Commerce Court West, if any of the above work is scheduled to take place, modified asbestos procedures must be followed. This procedure includes:

- Notify the Joint Health and Safety Committee in writing of the use of varied procedures.
- Notify workers that they are modifying, removing, cleaning etc. ducts in a building with asbestos-sprayed fireproofing however, ducts on the floor are non-asbestos containing.
- Workers are to be trained on this specific set of procedures and have asbestos awareness training.
  - Workers do not need to be trained in Type 3 Worker Training.
- Shut down HVAC system being worked on.
- Install drop sheets below areas of work. Drop sheets can be disposed of as non-asbestos waste.
- Disposable suits and respirators (P100 filters) must be made available to the workers. This PPE is optional and therefore not required.
- If a worker requests the use of a suit and/or respirator, the worker is to be fit tested and this equipment should be worn during the planned modifications.

- The use of power tools is strictly prohibited.
  - Tools to be used during duct modifications are restricted to power shears, battery assisted screwdrivers and hand tools including hammers.
  - Tool not to be used include hole saws, reciprocating saws and grinders.
  - If additional tools are required, please contact Pinchin Ltd.'s for consultation prior to commencing work.
- Ductwork removed for disposal can be disposed of as clean waste.

To view the full Duct Modification- Varied Procedures document prepared by Pinchin Ltd, please refer to APPENDIX VI.

#### 3.6.4 Working around Asbestos Containing Joint Compound

When working around Drywall Joint Compound present on the core & perimeter walls, columns, and ceilings in the Commerce Court Complex, certain precautions must be taken due to the presence of asbestos.

The regulatory guidelines apply to the following:

- Removal of vinyl wallpaper.
- Repair and skim coat walls as necessary to provide a smooth finish.
- Apply new finishes (paint, wallpaper, etc.) to walls.
- Install steel stud partitions against existing drywall walls finished with asbestos containing drywall joint compound.
- Removal of less than 1 square meter of drywall.
- Repair of void in drywall.

Since there is no disturbance of the existing drywall joint compound the above-listed procedures are not considered a regulated asbestos procedure and hence this work can be done by your normal trade contractor (no specific asbestos training or government notice required). It is important that the workers be notified, in some documented fashion, that the existing drywall joint compound does contain asbestos and that they should not disturb this material during their work.

To view the full Working around Asbestos Containing Joint Compound document prepared by Pinchin Ltd, please refer to APPENDIX VII.

#### 3.6.5 Replacing Fireproofing

Wherever fireproofing has been removed for any reason, it is to be replaced with asbestos-free fireproofing of an equivalent rating, to the approval of Commerce Court Property Management.

#### 3.6.6 Clean-Up, Removal and Disposal

The Contractor will be responsible for the clean-up, removal and disposal of all asbestos- contaminated waste from the project in strict conformity with Regulation 654/85. A copy of the asbestos disposal forms which are required by the Ministry of

Environment must be submitted to the Construction Services Department (also refer to section 2.5.3).

### 3.6.7 Completion of Work

All work areas must be cleaned, and all ceiling tiles must be re-installed at the end of each work period before space is re-occupied. Air quality testing is also required to be completed upon completion of work. A copy of Pinchin Ltd.'s Site Inspection Reports must also be provided to Construction Services (also refer to section 2.5.3).

Note: All work is subject to inspection provided by Commerce Court Security and Life Safety personnel and/or asbestos consultants employed by Commerce Court.

### 3.6.8 Discovery of Friable Material

Any unexpected discovery of friable material which may contain asbestos, during any work, shall be reported immediately to Commerce Court Security, at 416.364.6366 in addition to the notification required by the legislation to government authorities. Work in this area will then cease until Property Management authorizes the continuance of work.

### 3.6.9 Failure to Comply

Failure to totally comply with any of the foregoing rules and regulations, along with any revisions, which may be implemented from time to time and all aspects of Ontario Regulation 654/85 shall be deemed sufficient reason for Commerce Court Property Management to halt the work or dismiss the Contractor from the project. All costs incurred by Commerce Court Property Management, because of such action, will be the sole responsibility of the Contractor.

### 3.6.10 Occupational Health & Safety Act Asbestos Regulation

All Contractors working within the Commerce Court Complex who may disturb ACM are required to comply with the following:

Ontario Regulation 278/05, Regulation Respecting Asbestos on Construction Projects and in Buildings and Repair Operations (APPENDIX VII).

R.R.O. 1990, Reg. 838, Regulation Respecting Asbestos on Construction Projects and in Buildings and Repair Operations as amended, made under the Occupation Health and Safety Act, 1980, under the jurisdiction of the Ontario Ministry of Labour.

R.R.O. 1990, Reg. 347, as amended for asbestos, made under the Environmental Protection Act, under the jurisdiction of the Ontario Ministry of the Environment.

Transportation of Dangerous Goods Act, 1992 (TDGA, 1992), S.C, 1992, c.34 including Transportation of Dangerous Goods Regulations SOR/85/77 and subsequent amendments.

Commerce Court Complex - Asbestos Management Program, prepared by Pinchin Ltd.

Note: R.R.O 1990, Reg. 838 is the amended version of Ontario Regulation 654/85. All references to Ont. Reg. 654/85 are to be changed to Reg. 838.

### 3.7 CARPET LAYING

Carpets may not be glued to the floor, except when a “quick-release” type of glue is used, and the Landlord’s approval has been obtained. Installation of all carpet within the Tenant’s premises must be completed after normal business hours. Base building fans are to be turned on for a minimum of **twenty- four (24)** hours during and after installation to remove any odors emanated by carpet and adhesives.

### 3.8 CEILING GRID

Base building construction has erected the ceiling grid to typical floor ceilings. The Tenant shall be responsible for any damages to this grid due to Tenant work (refer to section 4 for specifications). Clips must be used to fasten interior partitions to the ceiling grid; **screws are not permitted to fasten partitions to the T-bar ceilings.**

### 3.9 CLEARANCE REQUIREMENTS FOR INSULATED GLASS UNITS

- Partition Walls cannot be built in front of the exterior wall glazing system such that replacement of the glazing units becomes encumbered. Partition walls/bulkheads can interface with the mullions of the glazing system provided the finished wall surface does not extend past the glazing framing width. A minimum of 2” clearance is required.
- Fixed or moveable furniture shall be placed/configured to ensure access to the glazing units is not limited should replacement of the unit be necessary. The required access includes: a clearance of 2 ft in front of the glazing unit and full floor height with direct access to the corridor having a minimum width of 2 ft.
- Should furniture and/or fixtures require removal for the Landlord to facilitate the replacement of the glazing unit, all costs for furniture / fixture relocation or removal are to be borne by the tenant. All proposed fit outs must be reviewed and approved by QuadReal.

### 3.10 COMMENCEMENT OF TENANT’S IMPROVEMENTS

#### 3.10.1 Inspection of Tenant Premises

- Prior to commencement of any Tenant work, an inspection of Tenant floors shall be performed by Tenant, their agents, and QuadReal Property Group.

- A signed letter shall be issued confirming acceptance of Tenant area and any damages or deficiencies shall be indicated at that time. No claims shall be considered for any items not identified in the acceptance letter.
- The Landlord shall issue verbal or written notice to the Tenant advising that all the conditions prerequisite to the commencement of Tenant work have complied with to the satisfaction of the Landlord. This notice shall be presented to the Tenant Contractor before he will be permitted access to the Premises to begin the Tenant work.

### 3.10.2 Inspection of Tenant's Work in Progress

- The Landlord, Agents, Architects, Engineers, and Consultants shall have unlimited access to Tenant premises for the purpose of inspecting the Tenant Work in Progress. Deficiencies under Tenant care can be addressed by the Landlord, Architects, Engineers or Consultants, and it is under their responsibility to correct the issue by the Tenant immediately.
- The Tenant's Contractor may issue revisions to the documents outlining regulations and procedures for Tenant Contractors and Sub-Contractors on the job site, as site conditions warrants.

After completion of Tenant work, an inspection between QuadReal Property Group and the Tenant floor/area is re-issued for final inspection. Any damage that may have occurred under the Tenant Contractor during execution of work shall be repaired by the Landlord's Contractor at the expense of the Tenant.

### 3.11 COMPLETION OF WORK (also refer to section 2.5)

- At the completion of work, the Tenant must provide the Landlord with a complete set of "as-built" sepia drawings and all close-out documents as noted in Section 2.4 and Section 2.5. of the LIM. All elements of the base building, such as light fixtures, ceiling, tiles, doors frames, and hardware that the Tenant removes with the approval of the Landlord, remain the property of the Landlord and must be delivered back to the Landlord in good working condition. The Leased premises must be left clean and in a "move-in" condition, which is accepted by the standards of the Landlord and base building cleaning Contractor. The Landlord's cleaning Contractor may be retained at the Tenant's expense to complete this work.

In addition to the foregoing obligations, **Tenants are also responsible for ensuring, before premises are occupied or re-occupied, that the following areas and/or items are cleaned post- construction:**

- Light fixtures and lenses
- Ceiling and ceiling tiles
- Floor tiles and carpets

- Corridor walls and doors immediately adjacent to the Leased premises
- Perimeter induction units (inside wet clean and outside)
- Lint screens and coil (cleaning shall be carried out by the Landlord's Base Building cleaners and charged to the Tenant's account)
- Inside faces of windows
- All service rooms
- Window Blinds (cleaning of the blinds shall be carried out by Base Building cleaning company, and charged to the Tenant's Account)
- The air filters for the floor air handling unit must be replaced following construction at the Tenant's cost
- Ducts located from main supply connection through premises
- Main "T" drain connections at the main building drain stack

### 3.12 CONTROLS

The existing Robertshaw zone controllers in the complex are no longer manufactured and are obsolete. Any new VAVs or zone controls being installed must be added to the new Base Building Distech automation system. Any existing zone controllers in the same area will need to be upgraded to communicate on the new automation system network. Please ensure MTI, the base building contractor, is adequately advised of all required programming for VAV units. Contact Larry Sobotka at MTI @ 905.513. 1953. These units must be tied into the Life Safety Matrix. The cost for the programming runs at approximately \$135.00 per hour plus HST. It is estimated to take **two (2) hours** per unit and rates may change without notice.

### 3.13 CONSTRUCTION NOISE

The Tenant's Contractor shall not perform any work during normal business hours **(Monday- Friday, 7:00 AM- 6:00 PM)** of which the noise is discernible to other Tenants or interrupts the use of their premises. The Property Management Office shall determine what level of noise is acceptable in the event of an occurrence.

### 3.14 COURTYARD PAVER PROTECTION POLICY

Courtyard paver repair is an expensive cost for the Tenants of Commerce Court.

The purpose of the policy is to reduce that cost and maintain the highest level of safety for pedestrian traffic by providing a procedure to be followed for anyone arranging for work, including for service Contractors, where vehicles are required to come up onto the Commerce Court Courtyard pavers.

All vehicles exceeding 1,500kg (3,300lb) driving onto the pavers around the complex are to do so only with the protection of ¾ inch plywood sheets to be moved with the vehicle as it travels. Sheets must be placed width-wise to ensure weight is distributed over three pavers simultaneously. Please note that the King Street pavers are the most fragile, as they are supported by stilts. Precautions should be taken in all areas nonetheless.



All vehicles not exceeding 1,500kg (3,300lb) driving onto the pavers are subject to the same policy; however, plywood protection is only to be applied to protect trench drain cover or tree pit cover pavers.

In all cases, authorization for this undertaking must be obtained from Commerce Court Property Management and specified in the appropriate Work Permit issued for the project. Authorization will include the specific route to be followed by the vehicle. It is recommended that the route is walked with the Contractor just prior to the work commencing so that the condition of the pavers can be established in advance by all parties.

Prior to work commencement, Contractors are to inform the Property Management representative arranging for the work that they must report to the main Concierge Desk in the West Lobby and advise the duty Security Shift Supervisor/Property Management representative BEFORE driving onto the premises. Wherever possible, Security personnel/Property Management representative should confirm the route and paver condition with the Contractor when they announce their arrival.

Any Contractor seen driving onto the pavers without permission and/or precautions having been placed into effect will assume all responsibility, including costs, for all paver repairs located along the route taken.

### 3.15 DAILY CLEAN-UP

Contractors must ensure that corridors are left free of debris and must remove dirt and marks from corridor walls, floors, doors, etc., on a daily basis. Where special cleaning is required to maintain the corridor's neat appearance, such cleaning will be done at the Tenant's expense.

### 3.16 DAMAGE

Once a floor has been handed over to a Tenant's General Contractor, the Contractor is responsible for the floor. All floor deficiencies will be confirmed in writing with mutual acceptance to be in perfect condition unless, prior to the start of any work, an inspection by the Contractor and a Representative of the Landlord determines otherwise. If during the construction period, should the Tenant's Contractor or other forces working for the Tenant cause damage to the premises or public areas of the building, the Landlord, at its option, will carry out repairs at the Tenant's expense.

### 3.17 DRILLING, CUTTING WORK AND X-RAYS

**Drilling or cutting openings of any type or size into the concrete structure of any Commerce Court building without the Landlord's pre-approved authorization is strictly prohibited.**

### 3.17.1 Proposed Drilling or Coring Locations

The Tenant and/or their Contractor must have the proposed location(s) of the drilling and/or coring reviewed and approved in writing by both the Landlord and the Landlord's Base Building Consultant. All proposed locations shall be submitted to the Landlord by the Tenant in the form of drawings.

Submittals are subject to review and approval by the Landlord and the Landlord's Base Building Consultant, both coordinated by the Tenant. The Contractor must also specify the company performing the x-raying, drilling and/or coring work, the equipment being used, as well as the range/floors impacted by the x-rays. Five (5) business days' notice is required by the Landlord.

### 3.17.2 X-Raying

The Tenant and/or their Contractor must employ a Radiography (X-Ray) Contractor to locate all embedded objects by means of an X-Ray of the concrete structure in the immediate approved location of the hole. All X-Rays must be completed between the hours of 12:00 AM and 5:00 AM and at the convenience of the Tenant(s) impacted by the work. The x-rays will be reviewed and approved in writing by the Landlord and the Landlord's Base Building Consultant prior to drilling or cutting openings of any size into the concrete structure of any Commerce Court building. The Tenant is responsible for all costs related to the services provided by the Landlord, its Base Building Consultant and the X-Ray Contractor. The Tenant is also responsible for the costs to perform the X-Ray required and associated fees.

The X-Ray Contractor must also place signage at all access points to the affected floors including stairwells and elevator lobbies outlining the safe working limits during exposure of the film.

### 3.17.3 Drilling and/or Coring

Drilling and/or coring work may only commence once written approval of the x-rays by the Landlord and its Base Building Consultant has been received. Drilling and/or coring must be performed between the hours of 12:00 AM and 5:00 AM and at the convenience of the Tenant(s) impacted by the work, with five (5) days advanced notice to the Landlord. Contractor is to notify the Building Control Operator to bypass smoke detectors within the area of work to prevent false alarms. Any access required into another Tenant's space must provide the Landlord three (3) business days' notice.

Precautions must be taken by the Tenant and their Contractor to ensure that materials do not fall on occupants or contents of the floor below and that all water is vacuumed away before draining to the floor below.

Damaged cast-in electrical wiring or plumbing must be immediately repaired by a Landlord approved Contractor at the Tenant's sole expense.



All abandoned openings larger than 3" in diameter are to be filled with concrete and guaranteed to be secure. Any openings up to 3" in diameter must be filled with fire stopping material that is specific to the application and size as per the ULC Listed Assembly.

### 3.18 DUCT MODIFICATION PROCEDURES IN COMMERCE COURT WEST

Duct modification work includes the removal of diffusers or VAV boxes, relocating diffusers from one location to another, cleaning dust/debris within the ducts and cutting existing ducts to accommodate the installation of new flex or branch ducting. In Commerce Court West, if any of the above work is scheduled to take place, modified asbestos procedures must be followed. This procedure includes:

- Notify the Joint Health and Safety Committee in writing of the use of varied procedures.
- Notify workers that they are modifying, removing, cleaning etc. ducts in a building with asbestos-sprayed fireproofing however, ducts on the floor are non-asbestos containing.
- Workers are to be trained on this specific set of procedures and have asbestos awareness training.
  - Workers do not need to be trained in Type 3 Worker Training.
- Shut down HVAC system being worked on.
- Install drop sheets below areas of work. Drop sheets can be disposed of as non-asbestos waste.
- Disposable suits and respirators (P100 filters) must be made available to the workers. This PPE is optional and therefore not required.
- If a worker requests the use of a suit and/or respirator, the worker is to be fit tested and this equipment should be worn during the planned modifications.
- The use of power tools is strictly prohibited.
  - Tools to be used during duct modifications are restricted to power shears, battery assisted screwdrivers and hand tools including hammers.
  - Tool not to be used include hole saws, reciprocating saws and grinders.
  - If additional tools are required, please contact Pinchin Ltd. for consultation prior to commencing work.
- Ductwork removed for disposal can be disposed of as clean waste.
- To view the full Duct Modification- Varied Procedures document prepared by Pinchin Ltd., please refer to APPENDIX VI.

### 3.19 EMERGENCY CONTACT

The Tenant and its Contractors are required to inform the Property Management Office of a name and telephone number for emergency contact in case of an emergency having to do with the Tenant's premise. Commerce Court's

**EMERGENCY PHONE NUMBER IS 416.364.2050.** The Emergency Phone Number must be clearly posted within the construction area.

### 3.20 EMERGENCY PROCEDURES FOR CONTRACTORS

This plan is designed to provide specific emergency procedures for all Contractors who work within the Commerce Court complex. Much can be done to minimize the probability of an emergency, and enhance life safety and property protection through awareness, attitude, good housekeeping and sound fire prevention and safety practices. It is the responsibility of all Contractors to be familiar with these procedures and to be alert to the identification and reporting of all hazards to ensure life safety and property protection. This plan covers:

- Fire Safety and Prevention
- Floods/Water Leaks
- Medical Emergencies
- Security Regulations

#### 3.20.1 No Smoking

Contractors are reminded that smoking is not permitted on Commerce Court property and that its 100% smoke free including the exterior. The smoke free policy also includes electronic cigarettes.

#### 3.20.2 Fire Prevention

Good fire prevention practices are effective methods of ensuring fire safety in the Commerce Court complex. To prevent fire from occurring, the following should be observed:

- Do not permit accumulations of combustibles such as construction debris in the work area, i.e., garbage, skids, barrels, drums, etc. Remove all accumulated garbage daily.
- No smoking regulations must be always adhered to.
- Avoid careless storage practices, i.e., ensure exit routes, doors and stairwells are not blocked by boxes, materials, equipment, etc.
- Ensure sprinkler heads are not obstructed.
- Exercise caution when near, using or storing flammable materials. Petroleum products should be in approved containers. Contractors must avoid having excessive amounts of flammable liquids on site.
- Turn off power and heat equipment when not in use
- Adhere to Cutting and Welding procedures outlined in this manual.
- Storage of compressed gas or liquid cylinders shall be in accordance with Section 5.6 of the Ontario Fire Code.
- The use of propane gas is strictly prohibited in Commerce Court.
- If the fire alarm pull stations are not operational, signage to this effect must be prominently displayed in the affected area.

#### 3.20.3 Fire Safety Emergency Procedures

- Upon Discovery of Fire

- Shut off power and heat equipment, if it can be done safely.
- Leave fire area immediately.
- Close all doors behind you.
- Sound the fire alarm by activating a fire pull station.
- Use the stairwells to evacuate the building to the courtyard or street. If you encounter smoke in the stairwells during evacuation, use the alternate stairwell exit provided. Do not use elevators to evacuate.
- Follow instructions of responding emergency personnel.
- Immediately contact the Commerce Court Emergency Line at 416.364.2050.
- Accidental Activation of Fire Alarm
  - Immediately contact Commerce Court Emergency line at 416.364.2050.
  - Alert them of your location and the cause of alarm.
  - Provide as much information as possible.
  - Remain at site to provide further information to Security Operations Centre or Emergency Response personnel.

#### 3.20.4 Exits

If an exit is unavailable for egress due to construction or repairs, temporary exit signs must be installed/posted to clearly identify alternate exit.

#### 3.20.5 Floods/Water Leaks

If a pipe ruptures or if there are visible signs of water leakage, identify the sources of the leak and stop the flow of water as soon as possible.

**The Commerce Court Emergency Line should be contacted immediately at 416-364-2050.** Please inform security of the problem and location.

Note: Contractors should maintain sufficient plastic sheeting to minimize any water damage from a leak.

#### 3.20.6 Medical Emergencies or Accidents

Serious medical emergencies call 911, to request emergency services.

Next, you **must** notify Commerce Court Security and Life Safety Services by calling the **emergency line at 416.364.2050**, so that they can attend the site to render aid and be prepared to escort emergency services to the site when they arrive.

#### 3.21 FASTENINGS

Tenant Contractors are not permitted to mechanically fasten to window frames, fire-rated walls or exterior walls containing structural air/vapor barriers. Clips must be used to fasten interior partitions to the ceiling grid; **screws are not permitted into T-bar ceiling.**

### 3.22 FEES PAYABLE BY TENANT

Fees payable by the tenant are based upon each individual lease agreement.

### 3.23 FIRE SAFETY SYSTEMS

When fire alarm system upgrades are included in tenant improvements, the tenant may choose to use our Life Safety & Suppression Systems consultant, Nadine International (refer to section 1.3 for contact information). Should the tenant choose to use another approved consultant or engineer, the tenant will be charged a fee of \$1000.00 plus HST per floor to cover the cost for Nadine International to review the tenant design fire alarm drawings and to update the fire alarm building permit drawings.

Should the Landlord receive any fines by any jurisdiction with authority caused by construction or renovations, all fines will be forwarded to the Tenant and/or Contractor for payment.

#### 3.23.1 Pull Stations

All fire pull stations must have a cover which has been approved by our Security & Life Safety Services group. There is a “cost plus administration” fee for all pull station covers. For additional information or to arrange purchase of covers, please contact Ralph Martell, Fire & Life Safety Supervisor, 416.364.7321.

#### 3.23.2 Relocating Fire Hose Cabinets

All work associated with relocating a fire hose cabinet must comply with the requirements of Section 3.2.9. of the Ontario Building Code. When relocating a fire hose cabinet, the cabinet connection to the standpipe must be reinstated to the same riser as in its original location. All valves installed must be ULC or FM Global listed. Old valves are not to be removed and reinstalled; only new valves can be installed using the proper tools. Victaulic connections on sprinkler or standpipe systems are acceptable.

#### 3.23.3 Sprinkler and Standpipe Drain Downs

This procedure is designed to ensure that a minimum level of life safety is always maintained. It details the procedure to be followed if a fire protection system has to be shut down or bypassed.

- All work on fire protection systems will only be authorized for Contractors who have a valid work permit. Exceptions will be made for emergency repairs.
- At least **two (2) business days'** notice is required for any sprinkler or standpipe drain downs.

- At least **seven (7) business days'** notice is required for any testing of fire protection or fire alarm systems.
- If a drain down of a sprinkler or standpipe system is required, the Contractor will contact the QuadReal Project Manager assigned to the project to request it. The Contractor will provide the necessary information to project manager who will make the necessary arrangements. No drain downs will be booked if the Contractor does not have a valid work permit. The Contractor will be billed for any costs that are incurred.
- Sprinkler systems cannot be drained down if one of the standpipes is drained down, and standpipes cannot be drained down if the sprinklers are drained down.
- Sprinkler Systems will only be drained between 6:00 PM and 6:00 AM Monday to Friday or on weekends. If a Contractor requires a drain down Monday to Friday, the system must not be drained until after 6:00 PM, with the contractor starting work at 7:00 PM and the system restored by 6:00 AM Standpipe work can take place at anytime, however the drain downs must be done after hours.
- A Standpipe system for a particular floor or area cannot be drained down at the same time as the Sprinkler System is drained down. One of these systems must be always maintained. While a Sprinkler System is drained down, Hot Work is prohibited to take place on the affected floor or area. If Hot Work is required to repair the Sprinkler System; this must be approved by the Fire & Life Safety Supervisor.
- When a Contractor requires a drain down, they are to communicate to the QuadReal Property Group Project Manager to request the drain down. The Project Manager will process the request and will issue a work order to the Mechanical Supervisor. To schedule a Sprinkler or Standpipe drain down, a request must be submitted to the Mechanical Supervisor a minimum of 72 hours (3 business days) prior to the time the drain down is required. An exception to the 72-hour requirement would apply if the requirements for the drain down are deemed an emergency. At least seven (7) business days' notice is required for any testing of fire protection or fire alarm system.

- The Mechanical Supervisor will determine if there are any other drains scheduled for that day, as no more than 3 Sprinkler drain downs, 1 Standpipe and 2 Sprinkler drain downs can be scheduled per day. No drain downs will be scheduled if the Contractor does not have a valid Work Permit. There is a cost applied to include administration fees and applicable taxes, for Building Operations Personnel to conduct a drain down and to restore the system.
- Building Operations personnel will drain down the requested systems prior to start of work. When the work has been completed, the Contractor must liaise with the Building Control Centre to arrange for the system to be refilled and to check for leaks.
- In the towers, the Contractor is responsible for refilling the system, using a small Jockey Pump to pressurize the system to check for leaks. The Contractor must advise when they are starting to refill and when they are finished refilling the system. When the Contractor advises the Sprinkler System is refilled, the Contractor must notify the Building Control Centre to have Building Operations Personnel respond to open the valve. When the Contractor advises that sub-level Sprinkler System work is completed, they must advise the Building Control Operator who will advise Building Operations Personnel. Building Operations Personnel must meet with the Contractor to confirm the work is completed, and to ensure that someone will monitor the affected area while the system is being refilled. The Contractor must remain on scene while the system is being refilled, to check for leaks from the sprinkler system.
- At the start of the workday, the Contractor must contact the Building Control Centre at 416.364.8025 to ensure the required systems have been drained and the alarms by- passed. This must be done on every workday before any work proceeds.
- All systems must be restored at the end of the workday. If for some reason a system cannot be restored, the Fire & Life Safety Supervisor must be advised so that alternate measures can be put in place.
- Commerce court Security Personnel will conduct hourly fire watch spot-checks of floors/areas that have been drained down. There is an hourly cost applied to include administration fees and applicable taxes, for security Personnel to conduct fire watch.

For additional information on sprinkler/standpipe drain downs, please refer to [Section 3.39](#).

#### 3.23.4 Testing and Maintenance (Pull Station and Magnetic Locks)

This procedure details the testing and maintenance requirements for pull stations and magnetic locks to include the guidelines when this can occur. When magnetic locks are removed, the associated door signage must also be removed. All new magnetic locks must have the associated door signage in place.

- The General Contractor is responsible for coordinating the testing of newly installed magnetic locks during the time periods permitted by Commerce Court Property Management. New magnetic locks are subject to a pre-test, with only the General Contractor and required sub-trades in attendance, and a test with a City of Toronto Building Inspector. Each new magnetic lock requires a Building Permit, and a City Inspector must test the magnetic lock for the Building Permit to be completed and closed. It is the responsibility of the Contractor to install the magnetic locks, arrange the testing, and to complete and provide all the necessary paperwork, with copies for the City Inspector and the QuadReal Project Manager. If there are deficiencies, or if the magnetic locks do not pass inspection, it is the responsibility of the General Contractor to take corrective action to resolve the issues and communicate to the QuadReal Project Manager.
- The General Contractor must contact the QuadReal Project Manager before attempting to schedule magnetic lock testing. The General Contractor must provide at least 7 business days notice prior to scheduling any testing. Testing must take place Monday to Friday between 10:00 p.m. and 6:00 a.m. for the towers and from 2:00 a.m. to 6:00 a.m. for the sub-grade (court and below). On weekends, testing can take place at anytime for the towers and between 2:00 a.m. and 6:00 a.m. on Saturday and from 2:00 a.m. to 8 a.m. on Sunday for the sub-grade.
- The pre-test and the test with the City Inspector must not be conducted on the same day or two consecutive days. An additional day should be allotted after the pre-test to allow the opportunity for the Contractor to address deficiencies prior to the test with the City Inspector. The pre-test is mandatory to make sure deficiencies are identified and corrected prior to the test with the City Inspector. If deficiencies are identified during the test with the City Inspector, the inspection may not pass. This will require another testing date to be scheduled with the City Inspector.
- When the General Contractor has completed the magnetic lock installation and needs to schedule the pre-test and the test with the City Inspector, they must contact the QuadReal Project Manager to review the testing requirements. The General Contractor must know how many magnetic locks

will require testing, and exactly where they are located. Also, advise if the City Inspector will want to test the emergency lighting, and activate a fire alarm without fire alarm tones, life safety (stairwell pressurization fans) and elevator recall by-passes in place if this information is known. The General Contractor to advise the dates and times they would like to schedule the pre-test and the test with the City Inspector. There may be a cost for an additional Building Control Operator to be scheduled to assist with the testing, subject to applicable fees and taxes at a 4-hour minimum. The General Contractor is responsible for all fees incurred.

- The General Contractor must have a qualified Electrical Contractor in attendance to assist with the testing. The property electricians are not responsible for assisting with the testing. The Security Systems Integrator should also be in attendance during the testing. The General Contractor must have the necessary paperwork in include the Can/ULC 536 letter, the Can/ULC 527 letter, and the Owner/Installer Certificate. There must be copies for the Inspector and for the QuadReal Project Manager.
- The General Contractor must provide the QuadReal Project Manager the results of the pre-test and the test with the City Inspector.
- On the day of the testing, the General Contractor organizing the testing must contact the Building Control Operator at (416) 364-8025, to provide notice of the testing and ensure they are prepared to assist. The Building Control Operator will advise the Security Supervisor. The General Contractor must notify the Building Control Operator prior to commencing testing and once testing is completed. During testing, the Building Control Operator will monitor all alarms and immediately notify Toronto Fire Services upon receiving a fire alarm not in the scheduling testing area. This is done immediately so that provisions for the safety of occupants, as described under the Fire Safety Plan, can be put into effect. Upon receiving a fire alarm, as described above, all testing must cease and will not resume until approved by the Security Supervisor.

Only qualified Siemens personnel are authorized to work on the Commence Court Fire Alarm System. "Qualified" means a representative of Siemens with CFAA certification.

### 3.24 GARBAGE

Corridors, exits, freight elevator lobbies and common areas must be kept clear at all times. Removal of all construction garbage is the responsibility of the Tenant's Contractor. Arrangements must be made for elevator time to remove construction debris to the loading dock. Because of limited space, debris must be immediately removed from the site by means of a non-marking rubber wheeled cart by the Contractor.



Removal of Tenant's construction debris will be scheduled between the hours of 6:00 PM to 7:00 AM. Bins will only be accepted on site during these hours. Booking of the service elevator must be made via the [Commerce Court Website](#) with a minimum of forty-eight (48) hours' notice and subject to availability. An Elevator Operator must also be booked to operate the elevator, which represents a cost to the project/Tenant. Tenants will be charged a cost of \$36.00 per hour, for a minimum of four (4) hours, plus applicable taxes and administration fees.

Note: Garbage of a flammable nature (e.g. paper) must not be allowed to accumulate but must be removed from the site as quickly as possible.

### 3.25 LIENS

The Tenant shall undertake to protect the Landlord and its interests against the placing of liens under the Construction Lien Act by the Tenant's Contractors and suppliers, and to discharge forthwith at its own expense any liens registered against the building and lands which arise as a result of the Tenant's work.

### 3.26 LOADING DOCK

The Shipping and Receiving area may be used for the unloading, pick up and delivering of construction equipment, materials and waste only and is not permitted between 8:00 AM and 5:00 PM on business days. Access to Shipping and Receiving is restricted to twenty (20) minutes. Any vehicle that exceeds the parking limit is subject to tagging and or towing at the vehicle owner's expense. Parking of personal vehicles is prohibited. Exceptions can be made for deliveries after 6:00 PM, weekdays when a large pick-up or delivery can be handled. In these cases, arrangements for reserving the service elevators must be made two (2) business days in advance by calling (416) 364-1267. Movement of equipment or materials through lobby areas is prohibited. There is **a height restriction in Shipping and Receiving of 12'0"** and as such no vehicle exceeding this height will be permitted access.

Note: To book the elevators, the "Elevator Operator and Loading Dock Booking" form must be filled out on the website and submitted by clicking on the "submit" button at the bottom of the form page found at [Commerce Court Website](#). Once submitted, the form will be electronically forwarded to Building Services for processing.

**Any vehicle parked anywhere in the complex without prior written authorization is subject to being tagged and towed, at the vehicle owner's expense.**

### 3.27 MECHANICAL, ELECTRICAL, AND COMMUNICATION ROOMS

The Tenant shall be responsible for cleaning and making good any damages to the Mechanical, Electrical and Communication rooms. In particular, floor drains shall not

be used for dumping of liquid garbage and all floor slab openings shall be replaced with fire stop material.

No Tenant equipment is to be installed in either room without written approval from the Landlord. Any additions/deletions to an electrical panel must be noted on panel index.

### 3.27.1 Riser Room Access for Main Telephone Room (MTR), Riser Rooms, and Rooftop

To ensure and maintain security in telecom spaces, including the main telephone rooms, riser rooms, and rooftop, all work must be approved by the property's Telecom Riser Management firm, RYCOM TPM, in advance. Rycom must be engaged, at the tenant's cost to conduct pre- construction and post- construction inspections and also assist in the management of all communication and data activity within the Riser Rooms. The Client/Contractor is responsible for all associated costs and must submit drawings and any other requested documentation to RYCOM TPM for approval before the work may begin. All requests require **forty-eight (48) hours** advanced notice.

RYCOM TPM can be contacted at 1-877-792-6687 or at [customercare@rycom.ca](mailto:customercare@rycom.ca).

### 3.27.2 On-Site Review Audit

Installations that require cabling to pass vertically through more than one (1) riser room and/or cabling that extends beyond riser rooms through the parking garage, concourse, or ground level require an On- Site Review Audit. Persons mandated to attend the site review are: a RYCOM TPM representative, the Landlord, the Contractor, and the Client. Subsequent to the audit, RYCOM TPM will provide a written report outlining all findings. At the Landlord's discretion, additional On-Site Review Audits may be required at the Client's/Contractor's sole expense.

An On-Site Review is also required for a new service provider requesting to establish a Point of Presence (POP) in the building. The On-Site review includes a site walk to determine potential allocations within the property and review the proposed route. A Telecom License Agreement will be executed following approval from Landlord and RYCOM. Installations will be scheduled following agreement execution. All Site Reviews are chargeable to the contractor.

### 3.27.3 Standards of Work (refer to APPENDIX I)

In addition to compliance with all relevant and applicable codes and standards, cabling must conform to the standards as shown below. Specifically, all floor slab penetrations must be smoke stopped and fire sealed. If a Contractor's work infringes on a conduit/penetration that does not comply with relevant codes and standards, it is the Contractor's sole responsibility to ensure that measures are taken to meet these requirements. Non-compliant penetrations will not be "grandfathered"; all work performed must be completely compliant.

- Work must be performed in a professional manner adhering to standards such as those published by BICSI and local building and fire codes;
- Cables installed in the building's horizontal floor space will be plenum rated/FT-6, regardless if the space is actually plenum or not;
- Contractors will replenish the firestopping in the riser sleeves that are used to route the cables, regardless of the previous condition of the firestopping. If cores must be drilled, all penetrations (wall or floor) must be x-rayed and approved by the Base Building Structural Engineer before work may proceed;
- Cables must be routed in conduit, cable trays or on J-hooks. Running cables over the ceiling tiles and light fixtures is not acceptable. All cables must be properly supported and "strain relieved";
- Vertical cables must be labeled on either end and on every floor and horizontal cables must be labeled every thirty (30) linear feet;
- Cables must be properly dressed.

If the Contractor fails to implement the above guidelines, then they will be asked to perform remedial action to correct the deficiencies. Failing to take corrective action, the Contractor will be barred from performing any work on the property until all deficiencies are corrected

#### 3.27.4 Return to Base Building Cable Abatement Management & Control (refer to Appendix I)

To comply with fire codes, all abandoned cabling within the complex and in the riser rooms is to be removed back to source. RYCOM TPM will be the only Landlord approved contractor eligible to complete this work, as cable abatement activities are being managed as a whole through the RYCOM TPM Program. RYCOM TPM shall be engaged for any return to base projects. As such, RYCOM TPM will be responsible for removing all abandoned cabling from the site. Cable abatement activities are billable back to the last tenant unless other arrangements have been made with the Landlord.

#### 3.27.5 Fee Schedule for Site Review

RYCOM TPM is to perform a Site Review meeting with all parties as required. It is recommended that the following parties attend the Site Review meeting: RYCOM TPM representation, the building operator, client representation, consultants, engineers, and the contractor performing the work. These parties will walk through the scope of work and collaborate on how the scope of work will be or has been conducted. Once the Site Review is completed, RYCOM TPM will provide a Site Review Report to all parties who attended, and a copy will be posted to the RYCOM TPM web portal.

FEE AMOUNT: \$525.00 - subject to change without notice

### 3.28 PAINTING

Painting within the tenant premises is permitted during business hours and does not require a HVAC shutdown. Electrostatic painting however, will require a HVAC shut down. Please note that if a complaint is received regarding noise or odor, work will have to recommence after hours.

### 3.29 PARKING

Building Management does not provide parking for Contractor personnel and there is no special area reserved for this purpose. Vehicles parked illegally on the property are subject to tagging and/or towing at the vehicle owner's expense. There is a paid parking facility within the complex; however, there is a height restriction of 6'0", as such no vehicle exceeding this height is permitted access.

### 3.30 PLUMBING AND METERING

Where plumbing is removed from Tenant premises, all water supply, drain lines and vent connections must be removed from the ceiling space back to the core riser and properly capped. During construction, plumbing drains are not to be used for dumping construction debris, paint, drywall compound etc. Once construction is completed, all washroom and janitor closet drains must be cleaned out to the building drain stack. All main "T" drains connected to the main drain stack must be cleaned after construction. If this is not completed, the Landlord will have it done at the tenant's expense.

Installation of water meter(s) will be required on all incoming lines to the Tenant's premises servicing any kitchens, private washrooms and emergency back-up HVAC equipment. All chilled water connections must have a BTU meter installed. Approved BTU specifications are available through Construction Services at 416.364.5010. All meter reading units are to be located in Base Building janitors' closets or Base Building riser rooms. Domestic cold-water connections are not permitted as a primary supply to any HVAC equipment. In addition, connecting to the base building domestic hot water supply is not permitted. Tenants must supply and install hot water tanks. Metering must be completed by the Tenant during any Tenant improvements where above ceiling work is required.

#### 3.30.1 Specification for BTU meter

BTU meters shall be manufactured by Kamstrup model # 601 c/w Lon communication option, sensors shall be Kamstrup model #PT500; flow meters shall be Kamstrup model # Ultra flow 65T. In large pipe applications flow meter may be substituted for insertion type, manufactured by Onicon, model# F1200 depending on size of line to be measured.

BTU meters shall be supplied and installed by the base building controls supplier and connected to the base building automation system for monitoring, reporting and usage calculations.

BTU meters are to be connected to all chilled water supplemental cooling equipment feeds.

### 3.31 PROTECTION OF UNITS BEFORE CONSTRUCTION COMMENCEMENT

Base Building induction unit enclosures shall not be used as a step or for storage of materials, etc. Repairs for damages shall be the responsibility of the Tenant.

### 3.32 PUBLIC SAFETY- CONTRACTOR COMPLIANCE

It is the Tenant's responsibility to ensure that the Tenant's Contractor observes and complies with all applicable construction/safety regulations. Any additional safety regulations imposed by an authorized representative of the Landlord must also be immediately and fully complied with. Failure to comply will result in the immediate suspension of the Work Permit and the Tenant will be held responsible for all resulting costs. The authority having jurisdiction may be notified.

The Tenant shall ensure that the Contractor and Sub-Contractors observe and enforce all construction safety measures as contained in the requirements of any federal/provincial legislation, regulations, municipal by-laws and requirements and the requirements of all other authorities having jurisdiction which may pertain to construction of the work.

The Tenant must ensure that their Contractor and Sub-Contractors comply with but not limited to all ordinances, the requirements of all Acts and Regulations with respect to health and safety including Occupational Health and Safety Act, RSO 1980 Chapter 321 (as amended) and Regulations for Construction Projects (as amended) made there under; and Workplace Hazardous Material Information System (WHMIS) Regulation, Ontario Regulation 644/88 including the following:

- Before commencement of work and throughout Contract, maintain on site and readily accessible to all those who may be exposed to hazardous materials, a list of all hazardous materials proposed for use on Site or Workplace together with current Material Safety Data Sheets (MSDS).
- Ensure hazardous materials used and/or supplies on Site are labeled in accordance with WHMIS requirements.
- Provide detailed written procedures of safe handling, storage and use of such hazardous materials including special precautions, safe clean-up and disposal procedures. Conform to Environmental Protection Act for disposal requirements.
- Ensure that those who handle and/or exposed to, or are likely to handle or be exposed to, hazardous materials are fully instructed and trained in accordance with WHMIS requirements.

### 3.33 SECURITY CONTROL- CONTRACTOR ACCESS

The Security & Life Safety Services group is responsible to manage access to the complex based on the principle that only authorized persons are allowed access to the complex. Authorized persons fall into one of three categories:

- A member of the public who is in any public area of the complex not engaged in any type of prohibited activity.

**Note: Work being conducted by a contractor which is not covered by a Commerce Court issued Work Permit (refer to Section 3.50) is considered as Prohibited Activity.**

- Any person or company in possession of valid Commerce Court Work Permit (refer to Section 3.50).
- Any person or company noted on a Commerce Court Authorization to Grant Access Form. Authorization to Grant Access forms must be completed by an authorized tenant contact. Forms can be found online at [Commerce Court Website](#).

Commerce Court Security & Life Safety Services reserve the right to ask contractors to produce one of the above, in order to ensure that person in question is authorized to be on site and doing the work they are doing. Failure to produce either a valid photo ID pass-card, Commerce Court issued Work Permit or having your name and/or companies name noted on a valid Authorization to Grant Access form may result in the work being stopped and the contractor in question being asked to leave the site.

### 3.34 SECURITY ESCORTS

A Security Escort is required when entering the space of another tenant. A minimum of 48 hours notice must be provided to book a Security Escort. A minimum of (4) four hours will be charged plus applicable taxes and administration fees. If 3 or more Security Escorts are required to work at the same time, a Security Supervisor may be required at an additional cost.

### 3.35 SECURITY OF LEASED PREMISES

Tenants may wish to install a card reader/magnetic lock system, however, must retain the approved Base Building Security Integrator. Contractors shall in no way prop open and/or alter any Tenant security device/door without the prior written notice of the Landlord. Should a door schedule modification be required, the on-duty Security Shift Supervisor should be contacted at (416) 364-5545.

### 3.36 SERVICE ELEVATOR

The service elevator is available, non-exclusively, for small deliveries and Contractor use between 8:00 AM and 5:00 PM on Mondays to Fridays via dollies, hand carts,

etc. Please note, the service elevator cannot be taken out of regular service or delayed during the day.

Large deliveries must be made after-hours deliveries by booking the service elevator. A minimum of forty-eight (48) hours notice is required and approval is subject to availability. An Elevator Operator must also be booked to operate the elevator, which represents a cost to the project/Tenant. Tenants will be charged a cost of \$36.00 per hour, for a minimum of four (4) hours, plus applicable taxes and administration fees.

Booking forms are available on the [Commerce Court Website](#).

For loads that exceed the load capacity of the elevator (see chart below), the supervision of an Otis elevator technician will be required at the Tenant’s expense. The movement of equipment or deliveries is restricted to service elevators only. Passenger elevators are not to be used. A fine may be levied against trades that are caught using the regular passenger elevator for construction purposes, without authorization (APPENDIX II).

### 3.36.1 Service Elevator Load Capacity

BUILDING	ELEVATOR #	DESIGNATION	MAX. WEIGHT CAPACITY
CCW	30	West Service Elevator	5000 lb.
CCW	31	West Service Elevator	5000 lb.
CCS	42	South Service Elevator	3500 lb.
CCS	44	Food Court Service Elevator	4000 lb.
CCE	51	East Service Elevator	4000 lb.
CCE	53	East Retail Service Elevator	4000 lb.
CCN	90	North Service Elevator	3500 lb.

### 3.36.2 Service Elevator Dimensions

- CCW Service Elevator
  - Width- 98 inches (250 cm)
  - Height- 120 inches (305 cm)
  - Depth- 63 inches (160 cm)
  
- CCW Service Elevator Door Opening
  - Width- 54 inches (138 cm)
  - Height- 109 inches (277 cm)

- CCN Service Elevator
  - Width- 67 inches (170 cm)
  - Height- 120 inches (305 cm)
  - Depth- 84 inches (213 cm)
- CCN Service Elevator Door Opening
  - Width- 44 inches (112 cm)
  - Height- 87 inches (221 cm)
- CCS Service Elevator
  - Width- 89 inches (226 cm)
  - Height- 108 inches (274 cm)
  - Depth- 50 inches (127 cm)
- CCS Service Elevator Door Opening
  - Width- 48 inches (122 cm)
  - Height- 84 inches (213 cm)
- CCE Service Elevator
  - Width- 78 inches (198 cm)
  - Height- 108 inches (274 cm)
  - Depth- 58 inches (147 cm)
- CCE Service Elevator Door Opening
  - Width- 42 inches (107 cm)
  - Height- 84 inches (213 cm)

### 3.37 SITE MEETINGS

The general Contractor is to arrange and record at regular intervals during construction, site meetings to include representatives of the Tenant, General Contractor, sub-trades and QuadReal Construction Services, in order to deal with any problems, alter or arrange schedules and update work progress etc.

### 3.38 SPECIAL LANDLORD'S CHARGES

In cases of specialized construction or renovation where the Landlord provides special facilities, equipment or services, special charges may be levied. The Property Management Office will inform the Tenant of such costs, whenever possible, before the costs are incurred.

### 3.39 SPRINKLER SYSTEM

All revisions to the base building sprinkler system must be approved by the Landlord or authorized personnel. The sprinkler control valve will be closed, and the sprinkler line drained down until completion of all Tenant revisions on each floor. All sprinkler systems components must be able to be made operable at the end of each day. During the construction phase, the existing sprinkler system must remain



in full operation at all times except when the system is being modified to suit the new sprinkler system layout. At the completion of each work period or day, the sprinkler system must be restored to provide full protection of the floor and refilled accordingly in a manner such that the fire pumps shall not start or cause the system to go into alarm. ALL sprinkler heads must be factory mutual compliant. Any fire hose cabinet to be relocated must be re- instated to the original riser.

**Note: Sprinkler and standpipe drain downs are subject to availability.**

### 3.39.1 Sprinkler Drain Down

The duration of a Sprinkler System drain down is generally one (1) hour to drain and one (1) hour to refill. All precautions must be taken to ensure false fire alarms do not take place. Contractors could be charged back fees from the Toronto Fire Services for responding to false fire alarms. Sprinkler work requiring isolation of occupied areas will not be conducted during normal business hours. The Landlord will arrange for Security Personnel to conduct fire watch in accordance with the building Fire Safety Plan. The Tenant is responsible to ensure that the relocation or addition of heads conforms to all applicable

N.F.P.A standards, I.A.O requirements and to all authority requirements. Tenants will be charged a cost for drain downs, in addition to a cost for security, applicable taxes and administration fees.

### 3.39.2 Standpipe (fire hose cabinet) Drain Down

The duration of a standpipe drain down is generally **two (2) hours to drain and two (2) hours to refill**. Tenants will be charged a cost for the drain down, plus applicable taxes and administration fees.

### 3.40 STAIRS AND ACCESS AREAS

The Tenant is responsible for cleaning and **making good of damages to stairs and areas used for access during** Tenant work. **Fire doors in stairwells shall not be wedged open by Tenant Contractors nor blocked with debris or material.** Any damages to elevator cabs, doors, doors frames, photo luminescent path marking material etc. shall be repaired by the Landlord at the Tenant's expense, unless otherwise agreed with the Contractor.

### 3.41 STATUTORY DECLARATION FORM

The Tenant and its general Contractor must complete and execute a Landlord Standard Statutory Declaration Form protecting the Landlord against any and all liens, charges or claims for any work performed or material furnished. Please refer to [section 2.5](#) for the project close-out requirements.

### 3.42 STORAGE AND DISPOSAL OF HAZARDOUS WASTE MATERIAL

The storage of hazardous waste material should not be stored at Commerce Court. The QuadReal Property Group Environmental, Occupational Health and Safety Coordinator can be contacted to discuss hazardous waste material.

### 3.43 TEMPORARY SERVICES

The Tenant through their Contractor is responsible for the distribution of temporary power and telephone service within the Leased premises during the fixturing period. The Tenant's Contractor will be responsible for repair of all damages and cleaning. Common areas and washrooms used by the Tenant's Contractor will be the responsibility of the Tenant.

#### 3.43.1 Power

Power will be supplied at the panels of the dedicated electrical/telephone rooms and will be billed to the Tenant's account at a pro-rata/square foot basis as outlined in the Tenant Lease.

#### 3.43.2 Telephone

The main telephone service to the building is through Bell Canada and any other communication requirements must be approved in writing by the Landlord. The Tenant and its Contractors requiring the use of a telephone must arrange to have telephone service installed within the premises. The Tenant and its Contractors will not have access to the Landlord's telephone.

### 3.44 TENANT CONTRACTOR(S) REQUIREMENTS

The Tenant is required to engage its own Contractors for the purpose of carrying out its leasehold improvements work. All Tenant Contractors are:

- Subject to approval by the Landlord.
- Must be in good standing with the provincial Workers' Safety & Insurance Board.
- Must utilize the base building approved Sub-Contractors for any Leasehold improvement work.

#### 3.44.1 City Permits

A copy of all permits must be delivered to the Landlord through the Tenant. The Tenant must immediately correct any work that does not meet the approval of the building inspector, even though the Tenant's drawings may have been approved previously by the appropriate government authorities and the Landlord. Any revisions to the approved drawings requested by such authorities must be brought to the attention of the Landlord immediately. Should the Tenant unduly delay the required correction(s), the Landlord may make the correction(s) at the Tenant's expense.

A copy of the permit drawings will be available at the Landlord's request.

#### 3.44.2 Approved Drawings

A set of print permit drawings must be kept on the Leased premises for the duration of the construction period, so as to be available for reference purposes to the Landlord's authorized representatives.

#### 3.44.3 Construction Schedule (refer to section 2.5)

The Tenant must provide the Landlord prior to starting with a construction schedule outlining the start-up date and completion date. The Landlord will also require a completed list of the Tenant's Contractors and sub-trades, which will be listed on a Contractor access form and registered with site security.

#### 3.44.4 Existing Finishes

All building finishes and carpets must be adequately protected to prevent any damage by Tenant Contractors. Damage to building finishes caused by Tenant Contractors will be repaired by the Landlord at the Tenant's expense.

### 3.45 TENANT SIGNAGE

Tenant signage for ground floor lobby directories, elevator lobbies and suite signage must be in accordance with the Landlord's design criteria for style, location and size.

Tenant signage requests for lobby directory signage as well as suite signage and elevator lobby signage on multi-tenant floors is processed through Tenant Services. Please note that our signage vendor requires a minimum of three (3) weeks to complete the order. All costs associated with the signage orders will be charged to the Tenant's account.

Suite signage and elevator lobby signage for single tenant floors is the responsibility of the tenant; however, all signage must be approved by Construction Services and Property Management prior to it being ordered and installed.

All requests for signage must be submitted to Tenant Services at [cctoservices@quadreal.com](mailto:cctoservices@quadreal.com) and should indicate the exact wording and spelling required.

#### 3.46 TIE-INS

The Tenant must obtain the Landlord's permission before installing any tie-ins mechanical, fire protection or life/safety systems, and before testing any such tie-ins. Where any tie-ins are made to existing services i.e., domestic water, sanitary, etc., provisions for future accessibility and isolation must be made, and are the responsibility of the Tenant or their Contractor. At the sole expense of the Tenant, the Landlord's fire safety consultant shall be retained to verify any and all fire system alterations. An addendum certificate must be provided to the Property Management Office. Any tie-in to a Security, fire and/or life safety system must be made by the authorized base building Contractor. In the case of a security system, the final tie-in

to the base building head end must be coordinated with the Security Technology Group.

### 3.47 WATER SYSTEM SHUTDOWNS

All requests for water system shutdowns (fire, domestic, chilled or condenser water, etc.) must be submitted in writing for approval at least **7 days** before the shutdown date to the Property Management Office.

### 3.48 WELDING AND ANY OPEN FLAMEWORK

Work that involves welding, metal cutting with a torch, soldering, grinding metal or any other activity that requires the use of a flame or generates sufficient heat or spark that could serve as a source of ignition requires the issuance of a Hot Work Permit. A Hot Work Permit must be issued to all contractors conducting Hot Work. Proposed work of this nature must be approved on a valid Work Permit with authorization to perform it.

Hot Work Permits are issued from the Shipping & Receiving Security Office. These permits must be issued for each Contractor conducting Hot Work, even if they are working on the same floor or area. The contractor must contact the Building Control Operator and request the exclusion of the smoke detectors in the proposed work area. Should the Contractor neglect to notify the Building Control Operator and a fire alarm is activated, the Contractor will be responsible for all associated costs.

The Contractor must have a 10lb ABC type Fire Extinguisher, in working order, within easy reach of the work area. This Fire Extinguisher must be the Contractor's own, separate from the Commerce Court Fire Extinguishers. If there are multiple Contractors conducting Hot Work in the same area, they must each have their own Fire Extinguishers.

Contractors must remove all combustible items and debris within a 35' radius of the work area. If there are large combustible items in the work area they must be removed or covered with fire resistant sheets. Flammable liquids in the work area must be removed. All openings in walls and floors must be covered with fire resistant sheets. If working on a wall or partition, combustibles must be moved away from the opposite side. If working on a wall or partition, ensure that covering is non-combustible. If working on equipment such as a tank or duct, equipment must be cleaned of any combustible items. If working on any fuel-powered equipment, flammable vapors' or liquid must be purged.

The Contractor must display the Hot Work Permit at the work area. When the work is completed, the Contractor must notify Security. The Contractor conducting Hot Work must conduct Fire Watch during and for 1 hour after the completion of Hot Work, including any break activity. Prior to allowing Hot Work to commence and after the Hot Work is completed, the work area must be inspected by security.

### 3.49 WORK PERMITS

No work will be conducted at Commerce Court without a valid Work Permit. Work permit request forms can be filled out online at the [Commerce Court Website](#). A complete and full description of all areas required, and scope of work must be submitted with **three (3) business days** notice. The permit allows access to only those areas which are designated on the permit. Permits will be authorized for no more than Twenty-eight (28) days at a time. It will be the Tenant's/Project Manager's/Contractor's responsibility to renew the permit if necessary. All trades, Sub-Contractors, etc. must also carry a valid work permit with them at all times while working within Commerce Court. Contractors are required to produce a copy of the Work Permit for inspection by security personnel at any time. A Work Permit can be produced in hard copy or on a smart phone or tablet.

If access is required to a riser room, a Rycom issued ticket must also accompany the work permit. RYCOM TPM can be contacted at 1-877-792-6687 or [customercare@rycom.ca](mailto:customercare@rycom.ca), please refer to section 3.27 for additional information.

Note: Work permits will not be approved until all applicable documentation outlined in Section

**2.5 has been received (i.e. WSIB, Insurance Certificate, drawings etc.).**

### 3.50 WORKING AREAS

All construction materials, tools, equipment and work benches must be kept within the Leased premises throughout the construction period. The securing of tools/materials is the responsibility of the Contractor. All public lobbies, corridors, washrooms and stairs shall be kept clear of construction materials at all times. Floor mats must be laid down at all exits and must be vacuumed regularly to minimize dust.

### 3.51 WORKING HOURS

Work other than hoisting of materials and noisy work may be carried out in the Leased premises from 7:00 AM. to 6:00 PM, Monday to Friday. Any work needing to be done at other times must be specifically agreed upon and arranged with the Landlord providing **twenty-four (24) hours** notice. All work not contained within the demising walls and exposed to the public must be enclosed by temporary full height, one side drywall hoarding as approved by the Landlord and painted to match the Landlord's standard colour. No work is to proceed in areas exposed to the public during normal business hours, these hours being generally accepted as of 7:00 AM. to 6:00 PM

# SECTION 4 – BASE BUILDING FINISHES & STANDARDS

## 4.1 BASE BUILDING FINISHES AND STANDARDS

- Ceilings
- Complex Tile
  - White, in lay 5/8" thick non-combustible acoustic panels "Fine Fissured" manufactured by Armstrong
  - Tile sized 27 3/8" x 27 3/8" x 5/8"
- Complex Grid
  - 28X28 custom punched, standard ceiling grid = USG DONN DX 15/16" Flat White

### **CCN Approved Alternative**

- CCN Tile
  - White, in lay 5/8" thick non-combustible acoustic panels "Fine Fissured" manufactured by Armstrong
  - Tile sized 24" x 24" X 5/8"
- CCN Grid
  - Suspension system consists of 15/16" CGC Donn DX grid, 24" X 24" layout

### **\*NEW 25 King Street West New Standard (2019 onwards) (Floors 10, 15, 17, 19, 20, 21, 23, 24, 25 & 31)**

- Ceiling Tile - Acoustic Panel Ceiling
  - AC-3 Armstrong Optima Square Tegular 1" Thick (3265PB). Used in public corridor.
  - Armstrong Ultima, Square Edge, White, size: 30" x 30". Used in service rooms.
- Ceiling Grid
  - Armstrong Suprafine 9/16 Tee and Shadow Molding #7889. Used in public corridor.
  - Fire spray: CAFCO Blaze Shield 2, and CAFCO Bond-seal (type EBS)
  - Fire spray paint colour: Pro Industrial waterborne acrylic dryfall (flat), Sherwin-Williams SW7020 (244-C7)

\*Note - Tenants are not to alter or deviate from the new base building finishes standard above at 25 King Street West.

#### 4.1.2 Washrooms

### CCW/CCE/CCS Base Building Standards for Washrooms

- Faucets
  - TOTO - Automatic Faucet
  - Model # TEL5AAC-10
  - **2007 New:** Sloan Optima System
  - Product No. EAF-200-P ISM,
  - Finish Chrome Plated
  
- Sinks
  - American Standard Ovalyn Lavatory Basin 4" c.c.
  - White
  - 2007 New: Undermount sinks Kohler Ladena Sink Model
  - No. K-2214, Finish White
- Wall-mount dispensers
  - Rubbermaid TC One Shot automatic foam dispenser
  - Black/Chrome
  - **Product code FG750411**
  
  - Rubbermaid TC One-Shot automatic foam dispenser
  - Low Profile Polished Chrome
  - **Product Code FG750339**
  
- Toilets
  - TOTO CT 708 EG
  - Serial # 969-279
  - Finish: Color 01 Cotton
  
- Urinal
  - Trimbrook Water Saver 6561 017
  - Finish White

### CCN Base Building Standards for Washrooms (Pre-2019)

- Faucets
  - TOTO - Automatic Faucet
  - Model # TEL5AAC-10
  - Thermostatically Controlled Faucet
  - Power supply is AC.
  
- Sinks
  - American Standard (# 7578 2000 Feb 21) Ovalyn under Counter Lavatory (*Same sink name as the old models but slightly changed*)

- Wall-mount dispensers
  - Bobrick B-22 All Purpose Lavatory Mounted (Manual pump)
  - Rubbermaid TC One Shot automatic foam dispenser
  - Black/Chrome
  - **Product code FG750411**
  
  - Rubbermaid TC One-Shot automatic foam dispenser
  - Low Profile Polished Chrome
  - **Product Code FG750339**

**\*NEW 25 King Street West New Base Building Standards for Washrooms (2019 onwards) (Floors 10, 15, 17, 19, 20, 21, 23, 24, 25 & 31)**

- Faucets
  - Sloan Basys Sensor Faucet EFX-250-BAT-PB-0.5GPM-MLM-IR-FCT finish polished brass.
  - PO Plugs: Zurn Solid Top, Open Grid Z8743-PC
  
- Sinks
  - Toto LT191 (G) Undercounter Lavatory colour: Colonial White
  
- Toilets
  - WC-1 Afwall Millennium FloWise Elongated Flushometer Toilet. Royal Sensor Flushometer Royal 111 ESS Hardwired Polished Brass.
  - Toilet bowl seat: Centoco Antimicrobial Institutional Commercial 500 Series AM500STSCCSS
  - Urinal: Americal Standard Decorum 0.125 GPF High Efficiency Urinal. Sloan Optima Royal Model Sensor Activated Flushometer Polished Brass Finish
  
- Soap pumps
  - Sloan Optima Soap Dispenser ESD-400-PB
  
- Partitions type and colour
  - InterCo Bobrick DuraLine Compact Laminate Solid Phenolic 1180 Series. Colour Formica Bleached Legno Matte Finish
  
- Paper tower dispensers
  - Bobrick Recessed Paper Towel Dispenser and Waste Receptacle B-39003, B-3803 and B-38034 in Barrier Free Washrooms and Universal Washroom
  
- Toilet paper dispensers
  - Bobrick Contura Series Surface Mounted Multi Roll Toilet Tissue Dispenser B-4288



- Ceiling paint colour
  - PT-2 Sherwin Williams SW7005 Promar 400 Flat
- Floor tile
  - TL-1 Foussana, Thala, Semi-polished 30cmx60cm, Stone Tile
- Wall tiles
  - TL-2 Maxfine White Calacatta, Polished 59"x119" Ciot.
- Lighting fixtures
  - 3G LIGHTING Pendant LINIA - model number (3G-4PLI-DIL2-L1-35K-120V-FL-XX-1C-S4)

*\*Note - Tenants are not to alter or deviate from the new base building finishes standard above at 25 King Street West.*

#### 4.1.3 Furniture Layout

The following minimum clearance spaces required for the Perimeter Induction System is applicable to all furniture types:

- 12" (Twelve Inches) is required in front of the enclosure
- 9.25" (Nine and a quarter Inches) is required above the enclosure
- A maximum 4.5" of overhang is allowed
- Consideration must be made for the location of the Induction Unit Control Valves. It is necessary to maintain clear access for servicing of these units.
- 12" (Twelve Inches) from the knee wall must be maintained in the instance of ceiling induction units

#### 4.1.4 Painting

- •The West Building elevator door paint spec:
  - SW 7570 Egret White
- The North Building elevator door paint spec:
  - Duranar Gold Exoti
  - UC52138XL/BC
  - PBG Manufacturer

#### **\*NEW 25 King Street West elevator door paint spec (2019 onwards): (Floors 10, 15, 17, 19, 20, 21, 23, 24, 25 & 31)**

- PT-4 Scuffmaster Ultra Clear, satin, master coating technologies. Colour SM8128 Solid Metal.

- Interior windows
  - Sherwin Williams Project #7036, colour #7675 Pro industrial Semi Gloss
  - Induction units
  - PT-1a SW 7671 On the Rocks, Semi Gloss
- Doors and frames (CO#84)
- Tenant and washroom doors and frames
  - Pt-6 Sherwin Williams WS 7675 Sealskin, product: All surface I Semi Gloss.
- Service doors
  - PT-7 Sherwin Williams SW 0023 Pewter Tankar, product: All surface I Semi Gloss.
- Elevator doors
  - PT-4 Scuffmaster Ultra Clear, satin, master coating technologies. Colour SM8128 Solid Metal.
- Lobby common walls
  - Sherwin Williams Pt-1 Colour Match #7036, promar 200 zero voc I eg-shel B20W12651- this is a colour match paint
- Lobby ceilings
  - Acoustic ceiling tile CO#119
  - AC-3 Armstrong Optima Square Tegular 1" Thick (3265PB). Used in public corridor
- Armstrong Suprafine 9/16 Tee and Shadow Molding #7889. Used in public corridor

*\*Note - Tenants are not to alter or deviate from the new base building finishes standard above at 25 King Street West.*

#### 4.1.5 Curtain Walls

Fastening directly to the curtain wall is not permitted (including mullions).

#### 4.1.6 Hardware

All door locks installed by the Tenant, on both entrance and interior doors, must be keyed to the building master and sub-master keying system using building

standard door hardware. Building door hardware shall be **supplied by Sargent** in our restricted keyway with a brushed stainless finish (32D). North building hardware shall be **supplied by Sargent** in our restricted keyway in a bronze finish (10B).

The system allows complete freedom to the Tenant with respect to locking arrangements for its offices, while providing access to each office at all times for both normal cleaning and emergency situations.

The Landlord's locksmith, who can be reached at 416.364.3478, maintains the master keying system and the records on key coding and distribution. **Outside locksmiths or lock manufacturers are not permitted to change the keying of any locks.** The Landlord's locksmith at the Tenant's expense must be engaged for the final keying. All door hardware must be removed by the base building Locksmith in order to maintain accurate records.

The Property Management Office must be notified before the installation of any card-access system. **Any Tenant door equipped with a card reader must have a building master key override.**

It is advisable that the Tenant contacts the Property Management Office before purchasing a hardware system to ensure that it is compatible with the base building Sargent restricted keying system. Door lock cylinders are not to be removed from the premises.

#### 4.1.7 Window Coverings

The Landlord provides Venetian blinds or Mecca shades throughout Commerce Court. These window coverings shall not be removed or replaced by the Tenant without Landlord approval. The specifications are as follows:

- CCW  
Solarfactive Products Ltd., 506 Grey/Black, 5% O.F.
- CCN
  - Solarfactive Products Ltd., 505 Mid Grey, 5% O.F.

#### 4.1.8 Signs (refer to section 3.45)

Tenant identification signs on ground floor lobby directories, elevator lobbies and adjacent to Tenant entrance doors must be in accordance with the Landlord's design criteria for such items as style, location and size. The cost of the signs will be charged to the Tenant's account.

**Note: Requests should be submitted approximately one month prior to the actual move- in date.**

#### 4.1.9 Marble Tile (Concourse Level)

- Rosso Lavento Marble - 12" x 12" - Polished for Retail Area Contact:  
Marble Granite Depot  
900 Caledonia Road  
Tel: (416) 787-0391  
Fax: (416) 787-0847

#### 4.1.10 Common Corridor

- **CCN Common Corridor Finishes**
- Ceiling Grid
  - See section 4.1.1
- Carpet Tile & Base
  - Interface style UR202 #126980250H in colour Flax #102963
- Wallcovering
  - Distributor is Metro Wallcoverings (Yvette Lambe-Edgar 416-529-4435), manufacturer is Patty Madden. Pattern is Azuki (#LXB-AZU 04) in colour Reflections.
- Light Fixtures
  - **Pot Light:** manufacturer is Cooper, model is Portfolio CD60423E-6CV142-LI-HB26 (Type 26W TTT 3500K), 6" compact fluorescent type c/w clear reflector and white trim 347V
  - **Exit Light "Hallway":** manufacturer is Beghelli, model is Ottica EXIT OT-E-L-WC- ROW-UDC
  - **Exit Light "Exit at Stairway Doors":** manufacturer is Beghelli, model is Ottica EXIT OT-E-L-E-ROW-UDC
- Doors and Frames
  - Frames to be painted SW0023 "Pewter Tankard" semi-gloss finish.
  - Doors to be painted SW6106 "Kilim Beige" semi-gloss finish.

#### **\*NEW 25 King Street West Common Corridor Finishes (2019 onwards) (Floors 10, 15, 17, 19, 20, 21, 23, 24, 25 & 31)**

- Ceiling Grid
  - See section 4.1.1
- Carpet Tile & Base (Floors 21 and 25 only)
  - Interface Carpet Tile - CT-101, Collection: Common Theme, style#:146250250H, colour: 103972 Onyx, size: 50cm x 50cm
  - 4" carpet base to match carpet tile
- Wallcovering
  - Interior windows: Sherwin Williams Project #7036, colour #7675 Pro industrial Semi Gloss

- Induction units: PT-1a SW 7671 On the Rocks, Semi Gloss
- Light Fixtures
  - 3G LIGHTING Pendant LINIA - model number (3G-4PLI-DIL2-L1-35K-120V-FL-XX-1C-S4)
- Doors and Frames
  - Tenant and washroom doors and frames: Pt-6 Sherwin Williams WS 7675 Sealskin, product: All surface | Semi Gloss. Service doors: PT-7 Sherwin Williams SW 0023 Pewter Tankar, product: All surface | Semi Gloss.

*\*Note - Tenants are not to alter or deviate from the new base building finishes standard above at 25 King Street West.*

### **CCW Common Corridor Finishes**

- Ceiling Grid
  - See section 4.1.1
- Carpet Tile & Base
  - Interface style 1425602500, colour Glacier #100533, size 50cmX50cm, in Ashlar pattern
- Wallcovering
  - **Wallpaper:** Distributor is Crown Wallpaper and Fabrics (1-800-268-1300), manufacturer is Vycon wall Covering. Pattern is Theory (code #Y46430TY, Low VOC vinyl, meets cal 01350. Colour: critical, weight: 20 oz, material type: II)
  - **Paint:** Distributor is Peerless Finishing Contractors (905-709-0596), manufacturer is Benjamin Moore. Colour is Latex Eggshell, PT-1 Moore 2121-70.
- Light Fixtures
  - **Pot Light:** manufacturer is Cooper, model is Portfolio CD60423E-6CV142-LI- HB26 (Type 26W TTT 3500K), 6" compact fluorescent type c/w clear reflector and white trim 347V
  - **Exit Light:** manufacturer is Beghelli, model is Ottica EXIT OT-E-L-WC-ROW-1-U- UDC
  - **Custom Fit for 28X28 Ceiling System:** manufacturer is Visioneering, model is SP4212-LRTG28x28LED-8XX-040L-347-P94-C70-F99 finish? Include wireless Encelium module.
- Doors and Frames
  - Frames and doors to be painted Sherwin Williams 7065 Argos semi-gloss latex

# SECTION 5 – BASE BUILDING SYSTEMS

## 5.1 MECHANICAL SYSTEMS

### 5.1.1 General Heating, Ventilating and Air Conditioning Systems (HVAC)

Any addition or relocation of thermostats, VAV boxes, diffusers etc. deemed necessary to accommodate the Tenant's floor plan shall be the responsibility of the Tenant.

Ceiling plenums are used for return air. Air must move laterally through the office area to the core area return shafts and smoke shafts. **If partitions extend to the underside of the structure, openings must be provided for the free movement of air sized at less than or equal to 350 fpm.**

All renovated floors have plain flat diffusers. All other floors have light troffer type diffusers.

Capped sanitary drains, plumbing vents and domestic cold water are available for all office floors for all four buildings.

All new controls shall be DDC. Existing controls are a combination of DDC and pneumatic. The design criteria for office space are as follows:

- In winter, 20°C - 24°C with 20% - 30% relative humidity.
- In summer, 23°C to 26°C with 40% to 50% relative humidity.
- General ventilation rate (outside air capacity) will be 0.15 CFM per square foot of occupied area (20 CFM per person with one person per 150 square feet).

The Tenant's engineers will be supplied with information about air supply quantities, which the Tenant design shall not exceed.

The Tenant shall not directly utilize the base building exhaust system to accommodate any special room use (i.e. print center).

### 5.1.2 Commerce Court Piping Identification and Valve Tagging

The Contractor is responsible to coordinate with our base building Technical Services team for all valve tagging. Inclusive please provide a valve tag chart. Please refer to Appendix IX.

### 5.1.3 Commerce Court West (CCW) 199 Bay Street & Commerce Court East (CCE) 21 Melinda Street

The office interior floors of the building will be air conditioned by variable air volume, supplied by central air handling units. Outside air will be provided to each

air handling unit and will mix with return air before conditioning. Air will be distributed through ductwork to thermostatically controlled, variable volume control boxes and introduced into the space through special spot diffusers. Some floors remain as constant volume (awaiting conversion) and the site survey and existing drawings will help determine which system is available. It is an option to each Tenant to convert the system over to variable air volume, as the entire infrastructure is completed for this to be feasible.

The office perimeter floor areas will be heated and cooled by induction units in continuous enclosure and thermostatically controlled. Primary air is fed from central air handling units. The induction units require a minimum 12 inches clearance from the front panel for proper operation and maintenance. Tenants are advised not to place shelving units immediately above these units as this will compromise the unit's operation. Perimeter thermostats will control both heating and cooling in sequence.

Commerce Court West and Commerce Court East have a supplementary condenser water system for Tenant use for the process of heat rejection for water cooled air conditioning units that are required to operate beyond the normal building operating schedule or capacity.

General exhaust system is available for Tenant's use upon Landlord's approval.

#### 5.1.4 Commerce Court North (CCN), 25 King Street West

The office interior floors of the building will be air conditioned by constant air volume and supplied by central air handling units. Outside air will be provided to each air handling unit and will mix with return air before conditioning. Air will be distributed through ductwork through two reheat coils for the floor, thermostatically controlled and introduced into the space through special spot diffusers.

The office perimeter floor areas will be heated and cooled by induction units in continuous enclosure and thermostatically controlled. Primary air is fed from central air handling units. The induction units require a minimum 12 inches clearance from the front panel for proper operation and maintenance. Tenants are advised not to place shelving units immediately above these units as this will compromise the unit's operation. Perimeter thermostats will control both heating and cooling in sequence.

Heat rejection from water cooled supplementary air conditioning equipment in the North building must be connected to a Tenant's own implemented heat rejection system.

#### 5.1.5 Commerce Court South (CCS), 30 Wellington Street

The office interior floors of the building will be air conditioned by constant air volume and supplied by central air handling units. Floors 2, 3, 4 and 5 have been converted to fan powered VAV boxes with DDC controls. Outside air will be provided to each air handling unit and will mix with return air before conditioning. The office perimeter floor areas will be heated and cooled by induction units in

continuous enclosure and thermostatically controlled. Primary air is fed from central air handling units. The induction units require a minimum 12 inches clearance from the front panel for proper operation and maintenance. Tenants are advised not to place shelving units immediately above these units as this will compromise the unit's operation. Perimeter thermostats will control both heating and cooling in sequence.

General exhaust system is available for Tenant's use upon Landlord's approval.

## 5.2 ELECTRICAL SYSTEMS

The following is an overview of the electrical design of each building in the complex. Each Tenant should review the information related to the building they intend to occupy. The following are the general conditions that are to be used by the client's Electrical Engineer when designing the client space. Tenants are not permitted to install Tenant equipment in our Riser and Electrical rooms.

**Tenants are to ensure that all redundant electrical services are removed back to source. Redundant services include, but are not limited to, conduits, cabling, wiring, switches, receptacles, controls and all services in slab raceway.**

### 5.2.1 General Conditions for Commerce Court Complex

#### 120/208 Volt services:

Where the Tenant's electrical system design requirements exceed 1.5 watts per square foot, the Tenant may be required to provide a transformer with primary feeds off of the existing 347/600 volt distribution system on the floor. Under these conditions, the existing 120/208 volt power panels shall be disconnected from the existing on floor distribution panel and reconnected to the secondary side of the transformer(s) to ensure all power on the floor is derived from a common transformer.

Tenant supplied 120 V/208 V electrical panels shall be 3 phases with a minimum 225A rating. The circuits shall be arranged to balance the load on each phase to within 5%. Panels located in the base building electrical rooms shall be painted to match building standards, (orange for 120/208 volts and blue for 347/600 volts). Panels located within the Tenant space do not require the above noted color coding.

### 5.2.2 Tenant Sub Metering System

Tenants are required to install, at their cost, Measurement Canada Approved METER MANAGERTM Electronic Sub meters supplied by Carma Industries Inc.

Electronic Sub meters for electricity measurement are required for all Tenant electrical services, including receptacle power, lighting and supplementary air conditioning units etc., unless stipulated otherwise by Property Management.



For further details on Sub metering, please contact Property Management or Carma Industries Inc. in Toronto at 416.260.4264 or Peterborough at 705.743.2401 for further details please ask for Sales or Customer Service.

### 5.2.3 Tenant Improvement/Renovation will include:

**Electrical System Section:** Lighting and Power panels for all Tenants shall be sub metered by the building approved sub metering system.

**Mechanical System Section:** Mechanical system power for all Tenants shall be sub metered by the building approved sub metering system.

**Telephone and Data System Section:** All electrical loads for data and communications shall be sub metered by the building approved sub metering system.

**Natural Gas or Water:** Natural Gas or Water may be added if pulse initiating flow measurement devices are purchased and installed by the Mechanical Contractor, at the Tenant's expense.

**Specification Standard:** Tenant's Electrical Contractor Specifications for Meter Changes/Additions.

### 5.2.4 Tenant's Electrical Contractor: Specifications for Meter Changes/Additions

The Electrical Contractor will supply and install Carma Industries Inc. digital sub metering for all Tenant Power and Lighting as outlined below. The Electrical Contractor will purchase the sub metering equipment and services from Carma Industries Inc., Toronto Office 416.260.4264 or Peterborough head office 705.743.2401.

The Electrical Contractor will supply and install:

- Conduit for the communications Local Area Network (LAN).
- Conduit for CT and PT leads. (CT-Current Transducer, PT-Potential Transformer) from the electricity sub meter location to the closest available Energy Monitoring Pod.
- Connectors, fasteners, and junction boxes for conduit.
- Mount 10"x10"x4" PT enclosures which house PTs and fuse blocks

**Note: Enclosure, fuse block, fuses and DIN rail will be factory assembled and CSA Approved by Carma Industries Inc.**

- Install all CTs on the phases corresponding to their assigned PTs as per the EMP wiring chart and individual CT serial numbers.
- Ensure that the white dot on the CTs points toward the power source.

- Connect line-side of PT fuse block to the CT power source using red, black and blue 12- gauge wire.
- Where large step-down CTs are required (over 400 amps), mount enclosures which house 5 Amp Transducers and Shorting Terminals.

**Note: The 10" x 10"x 4" Enclosure cw Shorting Terminals, will be factory assembled and CSA Approved by Carma Industries Inc. and will be mounted by the Tenant's Electrical Contractor.**

- Where large step-down CTs are required (over 400 amps), mount Current Transformers and connect current transformer secondary using red, black, blue and white 12-gauge wires to the 5AMP Transducer Enclosure.
- Ensure that CTs and PTs are accessible by Measurement Canada inspection personnel.
- Assist in the orientation of the Commissioning Technician and perform any corrections or wire tracing deemed to be necessary by the Technician from Carma Industries Inc.
- All conduit connections to the EMP will be installed in a manner which will not allow water to enter the EMP.
- Coordinate with Base Building Metering Sub-Contractor for access to EMPs enclosures that are Measurement Canada sealed.
- Contact the Base Building Metering Sub-Contractor to receive all enclosures, Cts, Pts and details regarding the required conduit and PT/CT installation instructions.

Acquire Carma Sub metering Installation Details from the Base Building Metering Sub- Contractor for installation drawings, specifications, etc., and comply with all requirements outlined in the Installation Details Sheets.

#### 5.2.5 Electrical Lockout/Tag Out:

Unauthorized or inadvertent operation of electrical control devices may cause injury to people working on or near the equipment. The following procedure should be observed when isolating and locking out electrical equipment and/or machinery. All electrical **equipment should be clearly identified as to the equipment controlled and the source of the power.** Electrical Contractor should be familiar with the terms and definitions applicable to the electrical equipment and lockout procedures.

#### 5.2.6 Power Shutoff and Lockout of Equipment

The equipment should be removed from service by actuating control devices, such as selector switches, manual starters START/STOP push button switches, etc. **(Special attention should be given to control circuits as they may be energized from a different power source, Capacitors should be discharged where applicable).**

The disconnection devices should be placed in the OFF (open) position, tested for potential, and should be padlocked. When the equipment has been locked out, each person who is to work on the equipment should be protected by personally placing their padlock on the disconnecting device. The key should remain with the person at all times while the lock is in place.

When the disconnecting device has been locked in the OFF position, the isolation of the equipment should be proven by activating the starting device to ensure that the correct disconnecting device has been opened and that the equipment does not start. Test system with a CSA certified potential indicator to ensure the system is isolated. Tester should be checked on a live circuit to assure it is functioning before the actual system check and repeated again after.

**A "WARNING" or "DO NOT OPERATE"** tag shall be attached to the padlock. It should include the name of the person placing the padlock.

When the work has been completed, each worker should remove the tag and their personal padlock from the disconnecting device.

**A padlock should only be removed by the person who installed it.** The responsibility for its removal should not be delegated to any other person.

The lock should be removed only when all work has been completed and the equipment has been inspected and found safe. On removing the padlock and tag, consider the equipment ALIVE, even though the disconnecting device may remain in the OFF (open) position.

In computer-controlled installations, a dysfunction cover should be placed on the appropriate button or key. Where possible, the computer control should be made inoperable, and physical lockout should be carried out at the switcher.

Where the local power authority must be involved in an isolation and lockout of a power source (such as a transformer), Landlord must be notified.

Where several people may be working on the equipment, a "lockout bar" shall be used if necessary.

**A "WARNING" or "DO NOT OPERATE"** tag shall be attached to each padlock.

### 5.2.7 Return of Equipment to Service

The worker should ensure that all isolating switches are in the OFF position. The final lock shall only be removed by the person who placed it.

Where applicable, the local power authority should be contacted and told that the work is completed and that the power may be restored. Permission for the restoration of power to the equipment shall be given by the authority before power

is restored. The request for restoration of power can be made by any of the people named on any permit which has been issued.

Where workers fail to remove their padlocks from the disconnecting device, they shall be required to return to the workplace and remove the padlock. If it is not possible for the worker to return to the site, the supervisor may remove it, provided either of the following conditions are met:

- The worker, whose padlock remains on the disconnect, advises the supervisor that the padlock can be removed with no danger to any person. In such instances, the supervisor should observe the procedure for "Return of Equipment to Service" before removing the padlock.
- The supervisor makes a personal inspection of the equipment and observes the procedure for "Return of Equipment to Service" and is satisfied that no hazard exists prior to removing the lock.

#### 5.2.8 Transformers

Transformers, where required, shall be 600 volt, 3 phase, 3 wire, K13 rated, to 120/208 volt, 3 phase, 4 wire to provide electrical power to outlets, and shall not be located in the base building electrical rooms and only in the Tenant premises, 120/208 transformers shall be **painted orange**.

Where transformers are required and installed by the Tenant, it is the Tenant's responsibility to provide appropriate ventilation for the size of the transformer installed.

All auxiliary heating, lighting and power must be metered through the building system. It is the Tenant's responsibility to add any additional meters to support these loads.

#### 5.2.9 Wire

No Aluminum conductors are allowed in the complex. AC/90 (B/X) cables will be limited to 10 ft from point of entry into partitions. All insulated conductors must be solid or stranded TWH 90 or better.

#### 5.2.10 Identification

All electrical panels and transformers are to be identified with lamacoids nameplates.

All 120V power junction boxes are to be identified by circuit and electrical panel of origin. All Fire alarm junction boxes are to be identified by a **red cover plate** and identified "F/A".

All 347V lighting junction boxes are to be identified by circuit and electrical panel of origin and colored **blue**.

### 5.2.11 Fastenings

All conduits, hangers, supports and ceiling mounted equipment must be supported independently from the slab above. **Sharing of anchors with the suspended ceiling supports is not acceptable.** All anchoring is to be completed after business hours.

### 5.2.12 Lighting

The Tenant's lighting load is limited to 2 watts per square foot. All base building fixtures have been retrofitted with energy efficient lamps and ballasts. Where the Tenant adds additional light fixtures, the use of energy efficient components shall be installed. All Tenant lighting, with the exception of emergency lighting, shall be motion sensor operated.

**Base building lighting sensors are controlled by 24 Volts A/C. All sensors installed in tenant premises are therefore required to be installed utilizing 24 Volts A/C. Any other control voltage is not to be utilized.**

**All light fixtures must have the base building approved ballast disconnect installed to meet the Canadian Electrical Code 30-308(4) and new National Electrical Code 410.73(G). Base building approved IDEAL Power Plug disconnect specifications are available through Construction Services.**

### 5.2.13 Base Building Lighting

Depending on the building in which the Tenant has Leased, the lighting connections may be either directly connected to the power source or connected through a modular system. Where modular systems exist, any relocated or new fixtures must utilize this system. **All emergency fixtures shall be directly connected to the power source. All light fixtures must be independently supported from the ceiling by means of closed link chain.** For base building lighting Specification's consult [Section 5.2.15](#).

**Base building lighting sensors are controlled by 24 Volts A/C. All sensors installed in tenant premises are therefore required to be installed utilizing 24 Volts A/C. Any other control voltage is not to be utilized.**

**All light fixtures must have the base building approved ballast disconnect installed to meet the Canadian Electrical Code 30-308(4) and new National Electrical Code 410.73(G). Base building approved IDEAL Power Plug disconnect specifications are available through Construction Services.**

### 5.2.14 Communications Cabling

Open ceiling cabling must be installed in accordance with building code plenum requirements. Therefore, all communications cabling installed in the plenum, not installed in conduit, must be Fire Test 6 (FT6) rated. **Any deviation from this will result in the removal of non-compliant cables at the Tenant's expense.**

Cabling installed in ceiling space **MUST** be independently supported from the slab by means of industry standard cable support hangers (**Cable Cat J hooks or equivalent.**) **No cable is to "rest" on light fixtures or ceiling grid.** The maximum space between supports is to be 5 ft with 4 ft being the preference. All cabling is to be installed parallel or at 90 degrees to the gridlines of the building. All cabling is to be installed to EIA/TIA 568 standards. The base building communications risers are deemed common areas and are for use by service providers only. **Tenants shall locate all horizontal cabling within their own premises.** Any Tenant cabling within base building communications rooms are to be identified by means of appropriate labeling.

**Where large volumes of cables are to be installed, the building preference is the installation of a cable tray system**

5.2.15 Lighting Specifications

COMMERCE COURT WEST:

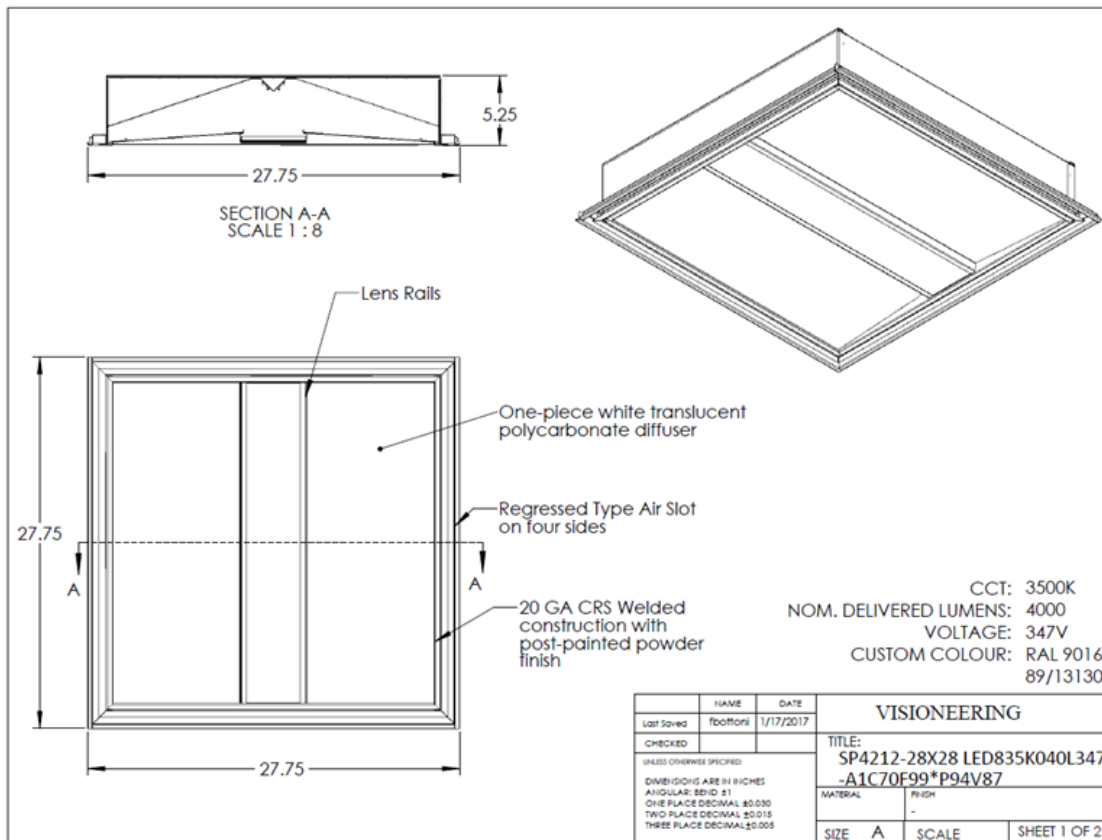

Description	CCN	CCE	CCS	CCW
<b>Regular Lighting</b>				
Make/Model: Peerless	Yes	Yes	Yes	Yes
Catalogue: CLAF-28-225-12.125	Yes	Yes	Yes	Yes
Maximum Watts: 55	Yes	Yes	Yes	Yes
Amp: 16	Yes	Yes	Yes	Yes
Operating Voltage: 347 Volt	Yes	Yes	Yes	Yes
Tenant Capacity: 2 Watts per sq. ft.	Yes	Yes	Yes	Yes
Fixture Size: 28 x 28 inch	Yes	Yes	Yes	Yes
Lamp Type: 2-25W, T8, 3000K	Yes	Yes	Yes	No
Lamp Type: 2-25W, T8, 4100K	No	No	No	Yes
Lenses: Acrylic	Yes	Yes	Yes	Yes
Supplied Fixtures	6/250 sq. ft.	10/500 sq. ft.	TBD	16/800 sq. Ft.
Reserve held by Landlord	None	None	None	None
Connection Type: NOCOM flexible modular wiring system	Yes	Yes	Yes	Yes
Low Voltage Lighting Control	Yes	Yes	TBD	Yes
Metered: Carma Industries	Yes	Yes	Yes	Yes
<b>Emergency Lighting</b>				
Operating Voltage: 347 Volt Emergency Power	Yes	Yes	Yes	Yes
Emergency Fixtures: Same as Regular Light Fixtures	Yes	Yes	Yes	Yes
Supplied Fixtures	1/200sq ft	1/200sq ft	1/200sq ft	1/200sq ft
<b>Exit Lights</b>				
Operating Voltage: 120 Volt Emergency Power	Yes	Yes	Yes	Yes
Manufacturer: <u>Beghelli, Ottica</u>	Yes	Yes	Yes	Yes
Lamp: LED	Yes	Yes	Yes	Yes
Supplied Fixtures: Exit lights at all stairwells are existing	None	None	None	None
<b>Power Systems</b>				
Tenant Capacity: 1.5 Watts per sq. ft.	Yes	Yes	Yes	Yes
Voltage Available	120/208-Volts via 600V,75Kva, K13 Type Transformers	120/208 Volt riser & panel	120/208Volts via 600V, 75Kva, K13 Type Transformers	120/208 Volt riser & panel
Voltage Available: 600V available for additional loads if necessary (Landlord approval is required)	Yes	Yes	Yes	Yes
Metered: Any additional load will require metering by Tenant	Yes	Yes	Yes	Yes
Electrical Rooms Per Floor	1	1	2	2
Distribution: Under floor Wire way System or Ceiling Distribution	Yes	Yes	Yes	Yes
<b>Communications Raceways</b>				
Communications Riser per floor (Not for use of Tenant equipment)	1	1	2	2
Distribution: Under floor Wire way System or in conduit within ceiling space. (No open ceiling cabling allowed in CCN)	Yes	Yes	Yes	Yes

COMMERCE COURT NORTH:

LUMINAIRE SCHEDULE		
TYPE	DESCRIPTION	LAMP
LT1A LT1B LT1C LT1E	<p>BASE BUILDING LUMINAIRE.</p> <p>VOLTAGE (V): 120V. DRIVER/BALLAST: 0-10V DIMMING. FINISH: BLACK HOUSING. NOTES: PROVIDE ALL MOUNTING ACCESSORIES AND END CAPS FOR A COMPLETE INSTALL. REFER TO DESIGNER DRAWINGS FOR MOUNTING HEIGHTS. REFER TO DESIGNER DRAWINGS FOR LENGTHS. FLUSH LENS OPTION.</p> <p>CATALOG SPEC: 3G-4PLI-DI-L2-L1-35K-120-DIM-FL-BK-1C-S4</p>	<p>TYPE: LED WATTAGE: DIRECT L2-5.25W/FT INDIRECT L1-3.5W/FT COLOUR TEMP: 3500K CRI: 90+ L70 (HOURS): 50,000 LUMENS: DISTRIBUTION: DIRECT/INDIRECT</p>
LT-2	<p>LED POT LIGHT.</p> <p>VOLTAGE (V): 120V-227V. DRIVER/BALLAST: 0-10V DIMMABLE. FINISH: WHITE. REFER TO DESIGNER DRAWINGS FOR FINISHES. NOTES: WHITE TRIM RING FLANGE W/ SPECULAR CLEAR FINISH. PROVIDE HB26 C-CHANNEL BAR HANGER, 26" LONG, PAIR.</p> <p>CATALOG SPEC: EATON LD4B-15-120V-D010-1010-80-35-M-0-LI-HB26</p>	<p>TYPE: LED WATTAGE: 15.5W COLOUR TEMP: 3500K CRI: 80+ L70 (HOURS): 50,000 LUMENS: 1500LM DISTRIBUTION: MEDIUM 50DEG</p>
LT-5	<p>LED WALL WASHER.</p> <p>VOLTAGE (V): 120V. DRIVER/BALLAST: 0-10V DIMMABLE. FINISH: WHITE TRIM. WHITE REFLECTOR.</p> <p>CATALOG SPEC: WASHLUX LED ONE LAMP-XICATO-E-95-35-W-W</p>	<p>TYPE: LED WATTAGE: COLOUR TEMP: 3500K CRI: 90+ L70 (HOURS): 50,000 LUMENS: DISTRIBUTION:</p>
HL-1	<p>ELEVATOR LOBBY HERITAGE FIXTURES.</p> <p>CONTRACTOR TO INVESTIGATE AND REPLACE BULBS OF EXISTING ELEVATOR LOBBY HERITAGE FIXTURES WITH NEW LED RETROFIT BULBS. 80+ CRI 3500K (10-15W). PROVIDE SHOP DRAWINGS FOR CONSULTANT REVIEW.</p>	<p>TYPE: LED WATTAGE: 15W COLOUR TEMP: 3500K CRI: 80+ L70 (HOURS): 50,000 LUMENS: DISTRIBUTION:</p>

### 5.3 STRUCTURAL SYSTEMS

A general description of the structure is provided to the Tenant by means of copies of selected working drawings. Such additional drawings or information as the Tenant may reasonably require may be obtained from the Property Management Office. Office floors have been generally designed to handle **100 pounds per square foot live load**. Unusually heavy loading situations, such as central filing areas, storage areas, vaults, safes, etc., must be specifically indicated, and details of projected floor loading supplied as part of the working drawings the Tenant submits to the Landlord. Plans for such unusual situations are subject to the Landlord's prior approval and structural engineer's review at the Tenant's cost.



#### 5.4 ELECTRONIC SECURITY MANAGEMENT SYSTEMS(SMS)

At Commerce Court, Security & Life Safety Services is responsible for the operation of the base building Security Management System (SMS).

The SMS is powered by Lenel's "On-Guard" access control system and Genetec's Omnicast IP video surveillance system. These systems seamlessly integrate synergistic technologies using open architecture design standards. The Lenel "On-Guard" access control system offers best in class features such as alarm monitoring, intrusion detection, asset tracking, information security integration, credential production and employee and visitor management functionality.

The current Commerce Court electronic SMS is comprised of the following components:

- Electronic door access control (credential (card, fobs etc.) readers, door locking and monitoring devices, etc.)
- VMS (visitor management system)
- Elevator floor access control
- Elevator intercoms
- PALs (pedestrian access lanes) controlling building lobby entry control
- PAL - elevator alarm integration
- Coordinated video and access control alarm response
- Various alarm points

Tenants have the choice of installing and Utilizing their own security system which could either be interfaced with and monitored by the base building SMS, or they have the option of having their own independent system monitored and supported by a third-party provider

For a Tenant system to be interfaced with and monitored by the base building SMS, the tenant must comply with the provisions noted in the Technical Standards Document version 3.2 and sign an Additional Service Agreement with the Landlord for the monitoring and annual licensing of the system.

Alternatively, Tenants who operate their own electronic security system which is not monitored by the Landlord are solely responsible for the management and operation of their respective systems.

As the installation of a Tenant security system is considered a leasehold improvement, Tenants must comply with the Leasehold Improvement Manual (LIM) as well as the Technical Standards Document 3.2. When installing a new, or managing an existing system, Tenants are free to select any base building approved security installation contractor listed in the LIM that they wish. However, the final connection of the Tenant system to the Base Building Security Integrator (BBSI); must be in conjunction with the Base Building Security Contractor (BBSC), for a fee.

Tenants with interfaced systems must also acknowledge that the standards noted within this document are subject to change from time to time, in order to keep up with evolving technology, and Tenants must undertake to ensure that their systems remain compliant with the current standard.

The Tenant will be fully responsible for all service related issues and it will be their responsibility to notify their chosen base building approved security installation contractor when repair and or modification services are required. Note that only the BBSC can access the base building SMS servers and all associated programming for a fee. Coordination may be required between the two contractors.

Tenants are strongly encouraged to enter into agreements with the vendor of their choice, in order to provide either a Service and/or Preventative Maintenance agreement for their system. Failure to have such an agreement will result in service being provided on a time and material basis, when required. Tenants are fully responsible to maintain and service their security systems and associated components at their own expense.

### **Tenant Systems**

- All Tenant security system installations shall adhere to guidelines indicated in the Commerce Court Leasehold Improvement Manual.
- It is not mandatory for tenant systems and related components to adhere to the exact technical specifications indicated in the SMS Technical Standards Document 3.2. However, all tenant systems that are intended to be monitored and or controlled by the by the Commerce Court SMS shall adhere to all general, product and execution guidelines indicated in the SMS Technical Standards Document 3.2.
- Tenant systems that do not adhere to the general, product and execution guidelines as indicated in the SMS Technical Standards Document 3.2 will not be monitored and or controlled by the SMS.
- Any deviation from the SMS and/or Contract Documents must be approved by the Senior Manager of Security and Life Safety.

#### **5.4.1 Work Permits**

A Work Permit must be issued by the landlord, prior to the commencement of any work. In order to apply for a Commerce Court work permit, the tenant's contractor must ensure that they are in full compliance with Section 2 of the LIM, as well as any other relative section. In addition, the following criteria must be followed:

- **Submission of Engineered Drawings (refer to Section 2.4)**

Tenants or their designers/contractor must at their cost, submit an engineered drawing for review, which clearly shows at a minimum the following:

- o the location of devices being added or removed

- o all cable runs and termination points
- o all electrical hook up

### **Commissioning**

All work will be subject to commissioning by the base building security system engineer, Lattice Engineering Inc. at 416-219-9421. The tenant will be invoiced accordingly for the commissioning of their system/devices by the landlord's inspector. Tenants will be charged at a rate of \$125.00 per hour, plus applicable taxes and administration fees. You must allow **ten (10) days'** notice to set up an appointment with the base building security system engineer to schedule a final commissioning of the system.

Commissioning will take place as many as **two (2) times:**

- Prior to the closing up of any confined spaces, walls and/or ceilings containing any component of the SMS, the tenant's contractor/designer must provide Security & Life Safety Services with at least ten **(10) business days'** notice, so that a partial verification/commissioning of the work can take place.
- Once the work is completed and prior to it being connected to the SMS, it must be commissioned to ensure compliance with the SMS Technical Standards Document. Any work that does not meet the standards or fails to pass the owners commissioning/inspection process will not be interfaced with the building SMS. If this occurs, any deficiency must be corrected to ensure that the work is fully compliant prior to it being connected to the Security Management System (SMS).
- As-Builts (please refer to Section 2.5)
  - o At the completion of the project, the tenant's contractor/designer must provide a complete set of "as-builts" (CAD drawings as well as hard copy) before the work order is closed. Failure to provide the required "As-builts" might result in the system being disconnected from the SMS.

#### 5.4.2 SMS Technical Standards Document

Copies of the *SMS Technical Standards Document* can be obtained by any authorized tenant by sending an email request to Tenant Services at [cctoservices@quadreal.com](mailto:cctoservices@quadreal.com).

- It is strongly recommended tenants ensure that their security vendors note in their formal proposals that they will be adhering to the current version of the Commerce Court Leasehold Improvement Manual as well as the SMS Technical Standards Document.



- Tenants must ensure that they are always using the most current version of the SMS Technical Standards Document. The current version issue date is **Version 2.1**.

# SECTION 6 – RETAIL GENERAL CRITERIA

## 6.1 RETAIL ARCHITECTURAL

The General Criteria establishes ground rules which apply to all Tenants. These Criteria encourage a strong visual identification for each Tenant's merchandise within a unified surrounding. This section describes these ground rules in general. The following sections describe in detail each component of the Tenant's merchandise presentation. The Tenant should refer to the Base Building Drawings and Tenant shell drawings for specific information regarding the Leased premises.

The Tenant shall take field measurements to verify all dimensions.

The Tenant's store will be designed, fabricated, and installed by the Tenant unless otherwise noted and subject to the Landlord's written approval. Metal stud framing with non-combustible drywall is the base construction of the demising partitions. All drywall partitions are non-load-bearing. The demising wall end will be constructed by the Landlord. This construction varies within the project. Applicable details are shown on the Details Section for each storefront. The bulkhead above the storefront will be constructed by the Landlord unless otherwise agreed to. The Tenant may not paint or add any additional finish materials to this bulkhead. Compatibility with adjacent and previously approved storefronts will be considered as one of the criteria for approval. The Tenant storefront construction must be set back inside the Lease line.

## 6.2 RETAIL MECHANICAL SYSTEM

The Landlord has identified on the Tenant Shell Drawings available capacities, if any, within Leased premises. If the Tenant's design requires additional capacities, the Landlord upon receipt and review of a comprehensive drawing submission, will advise the Tenant of necessary upgrade and associated costs, such costs shall be the Tenant's responsibility; however, the Landlord elect to perform or require that the Landlord's Contractor perform such work at the Tenant's expense.

### **Retail Base Building services provided for the Tenant's use include, but are not limited to:**

- Plumbing, ventilation, domestic cold water, natural gas, washroom exhaust, sprinkler system and chilled water connection.
- All equipment and items, such as isolation valves and pressure regulating devices, necessary to
- extend service to satisfy the Tenant's needs, must be provided at the Tenant's expense.

- AU domestic hot water is to be generated locally by the Tenant.
- If the Tenant's mechanical design requires service capacities beyond those provided by the Landlord, the Landlord may decide (after review of the Tenant's comprehensive drawing submission), to perform the necessary upgrade at the Tenant's expense. Such upgrading will not be performed by the Tenant under any circumstance unless agreed to otherwise.

### 6.3 RETAIL HEATING, VENTILATION AND AIR CONDITIONING

Except for redundant in-store ductwork associated with heating and cooling an existing premise scheduled for renovation, the Tenant is not to remove, alter or relocate any other in-store ductwork without the prior consent of the Landlord.

The Tenant shall provide air balancing of the HVAC and exhaust system using the Landlord's Contractor; the air balance report will be reviewed by the Landlord's Engineer at the Tenant's expense.

The air distribution within the premise shall be executed by the Tenant and shall include ductwork, dampers, diffusers, grilles, and 1" thermal insulation with a vapor barrier.

Where a drywall ceiling is installed, the Tenant must provide a 24" x 24" access panel to gain access to volume air dampers, reheat coils, air handling units, sprinkler valves, flow switches, etc. The Tenant must verify, with the Landlord, the location, size, and quantity of access doors required.

Where required by Code, smoke detectors shall be duct-mounted on the Tenant's mechanical equipment at the Tenant's expense.

Tenants are cautioned not to block or impede any diffusers in mall bulkhead soffits at storefronts.

The use of fire stop flaps is not permitted; where required by governing codes, fire dampers must be used.

Additional exhaust requirements shall constitute the removal of fumes and odors unacceptable for re-circulation and/or by Code.

Where water-cooled equipment is permitted for cooling, Tenants are required to insulate condensate drain lines.

### 6.4 RETAIL EXHAUST

Exhaust hoods shall be provided as per Code requirements or as determined by the Landlord's Engineer. Exhaust systems, including hoods, shall be installed as per current NFPA Codes. Use of a sprinkler system for hood extinguishing will not be permitted. Only CO<sub>2</sub> or other chemical extinguishing systems are permitted. The



Landlord's Contractor shall install a tie-in to the Landlord's Fire Alarm System, where required, at the Tenant's expense.

#### 6.5 RETAIL GAS

It is the responsibility of the Tenant to apply for their individual gas meter.

#### 6.6 RETAIL PLUMBING

Under no circumstance shall the Tenant or Tenant's Contractor install additional plumbing through the structural floor slab without prior written approval from the Landlord.

All plumbing vent lines are to be group vented to a point as approved by the Landlord.

High water users may be required by the Landlord to install a check meter at the Tenant's expense.

Flood drain traps must have seal priming.

Grease interceptors and/or "hair" baskets shall be installed by the Tenant where required by Code or as determined by the Landlord's Engineer.

#### 6.7 RETAIL SPRINKLER SYSTEM

The Tenant must design the sprinkler system and layout within the premises. The system must be compatible with the Base Building sprinkler system and in accordance with all applicable requirements of the appropriate authorities. All installations must comply with NFPA 13. Where applicable, existing sprinkler piping shall be adjusted to suit new head locations. Pipe sizing shall be adjusted as required to comply with NFPA 13. To ensure the granting of Occupancy Permit, Tenants must have their sprinkler design certified by the Tenant's Engineer. **The Landlord's approved Sprinkler Contractor must be retained for any work at the Tenant's expense.**

#### 6.8 RETAIL ELECTRICAL

Power supply capacities and distribution details to the Leased premises are indicated on the Tenant Shell Drawing.

If the Tenant's design requires additional capacities, the Landlord, upon receipt and review of a comprehensive drawing submission, will advise the Tenant of necessary upgrade and associated costs. Such costs shall be the Tenant's responsibility; however, the Landlord elect to perform, or require that the Landlord's Contractor perform, such work at the Tenant's expense.

It is the responsibility of the Tenant to supply and install all new and necessary electrical hardware equipment and Labor within the Leased premises as required by Schedule "C".

The Tenant must conform to the requirements of the Electrical Safety Code plus the rules and bylaws of all authorities having jurisdiction.

All materials shall be new, CSA approved, bear the CSA stamp, and be commercial grade.

Workmanship must be to the satisfaction of the Landlord. If it is not, the Landlord may elect to have the installation modified at the Tenant's expense.

A variety of lighting qualities to best suit the variable merchandising uses and physical conditions existing throughout the project are required.

Stores with merchandise display, either in a display window or free-standing, will require the following:

- Tenants shall provide a high level of incandescent illumination within Design Control Area. Only track-mounted or recessed fixtures are to be used within this area.
- All fixtures are to be of high standard approved by Landlord.
- No exposed fluorescent light fixtures will be approved within the Tenant's premises. Fluorescent light fixtures must be fully concealed from view.
- Within the Leased premises, if base lamps (incandescent or fluorescent) are used, the Tenant must shield these fixtures with a baffle design so as to shield the lamps from the mall at 5'-6" unless level, otherwise approved by the Landlord. The Landlord reserves the right to adjust such baffles after installation is completed, should such exposed lighting cause conflict with the common area design.
- All illuminated signs or graphics and incandescent lighting within the Design Control Area will be on separate time clocks connected to the Tenant's distribution panel. Hours for operating the aforementioned lighting and signs shall be determined by the Landlord.
- Electrode connections for neon tube-type lighting must be kept out of reach of the general public.

Food Court and Food-Use Tenants are required to design decorative and accent lighting which emphasizes their food displays. Only incandescent light fixtures will be permitted within the serving area.

Lighting of menu boards and storefront signs, other than neon, for Food Court Tenants must be done with recessed, track-mounted, low-voltage light fixtures and such fixtures will be subject to Landlord approval.

For further merchandising uses such as restaurants, cafes, bars and/or other uses that require a specific mood-type lighting to create the desired atmosphere, will be subject to approval of such by the Landlord.



## SECTION 7 – STORE FRONT CRITERIA

### 7.1 EXTERIOR STORE FRONTS

These Storefront criteria applies to all exterior retail frontage within the complex. This includes shops and restaurants with exterior windows along Bay and Wellington Streets, and shops and restaurants in Commerce Court South and East with exterior windows facing the Court level. The exterior storefront, greenhouses, entrances, and glass canopies must not be modified in color or finish. A drywall soffit is installed behind the storefront by the Landlord, where applicable. Tenant's ceiling must about this soffit. No continuous fixtures or walls may be constructed within the display window soffit area. Tenant must creatively merchandise all exterior display windows. Merchandising concepts, fixtures and display lighting should be included as part of Tenant's preliminary submission. The use of curtains, drapes and other shielding within the Tenant's exterior show windows or greenhouse is not permitted.

### 7.2 RETAIL STOREFRONT

The storefront entrance secured at the Closure Line may be provided by the following means:

- Full height, single track, frameless glass sliding doors, bottom and top rails only in approved finish;
- Full height swing frameless glass doors on pivots, bottom rail and top patches in approved finish.

A maximum of 10'-0" of the storefront width may be clear opening, with a minimum clear opening width of 6'-0". For storefront widths exceeding 25'-0", a maximum of two entrances may be permitted with Landlord's approval, with each entrance a maximum of 10'-0" clear opening in one frontage. Maximum of 50% of storefront width may be open.

Within the Design Control Area, Tenants may provide showcases fixed into position. Showcases shall be in approved materials and shall be internally illuminated.

Storefront base to be 4' high in approved material. Generally, the Tenant's storefront is to be located on the Lease Line, although the Closure Line (door line) is to be set back 3'-0" from the Lease Line.

Display windows will be selected from base building materials, list of approved materials, or alternate materials approved in writing by the Landlord.

Edges of the joints for frameless storefronts shall be ground and polished and sealed with clear silicone sealant.

When opaque materials are used within the storefront design, the balance between opaque and transparent materials will be to Landlord's approval. The use of curtains, drapes and other shielding devices within the Tenant's storefront is not permitted.

Tenant's storefront line is generally 8'-0" h. between floor and metal band, top fixing of glass on storefront line to be concealed in 8' metal band.

Storefront on Lease Line to be one of the followings:

- Fixed glass with 4" high base, clear silicone butt joints to vertical edges of glass. No exposed clips or moldings shall be permitted.
- Fixed glass with Mylar on glass, paint, applied gold- or silver-leaf, solid mirror with portion of backing removed for display or alternate to Landlord's approval.
- Fixed glass in steel sash, Duracron finish to steel parts in approved color.
- Solid elements selected from base building materials or list of approved materials, upon approval in writing by the Landlord.
- A drywall soffit must be installed behind the storefront by the Tenant. Tenant's ceiling will about this soffit.

### 7.3 RETAIL DESIGN CONTROL AREAS

To ensure a high standard of presentation by each Tenant, and necessary continuity of base building design, the Landlord has located Design Control Areas within the Leased Premises, noted on the shell drawings. The Design Control Area is the area within the Leased Premise that adjoins the common area of the project and/or affects appearance of the building. Particular attention shall be given by the Tenant to the visual organization of the Design Control Area as well as the rear and side walls of the sales area. Graphics, signs, materials, colors, finishes and lighting shall all be submitted for approval. **ALL AREAS EXPOSED TO PUBLIC VIEW ARE ESPECIALLY SUBJECT TO APPROVAL BY THE LANDLORD.**

Any penetration or alteration of materials installed or prescribed by the Landlord in this area is not allowed. Columns at the Lease-Line and within the Design Control Area are finished by the Landlord. Any attachments to these columns are not allowed. Columns within the Tenant premises but not within the Design Control Area will be finished by the Tenant. The Tenant is advised that certain fixed base building electrical and mechanical services passing through the Leased Premises have been established. The Tenant must accommodate these components within the design and ensure that appropriate access is provided.

### 7.4 COMMERCE COURT NORTH STORE FRONT

The Commerce Court North Storefronts are in the historically important section of the Concourse. The original vaulted ceilings, finely detailed marble floors, and stone demising piers will be maintained. The intent of the storefront criteria outlined here

is to enhance this historic character. The Tenant must not modify the color or finish of any elements of the storefront construction.

The storefront entrance secured at the Closure Line will be provided by an 8'-0" high swinging, framed glass door on pivots, with metal finished in Duracron baked enamel. Storefront base to be 10" high in Rosso Levanto Marble. Generally, the Tenant's storefront is located on the Lease Line, although the Closure Line is set back 2'-0' from the Lease Line.

Within the Design Control Area, Tenants may provide showcases fixed into position. Showcases shall be in approved materials and shall be internally illuminated. Display windows will be constructed from Rosso Levanto marble and framed clear glass with metal finished in Duracron baked enamel. Display window glass area may be subdivided from inside upon approval in writing by the Landlord.

When opaque materials are used within the storefront design, the balance between opaque and transparent materials will be to the Landlord's approval. The use of curtains, drapes, and other shielding devices within the Tenant's storefront is not permitted.

#### 7.5 COMMERCE COURT NORTH STORE FRONT DESIGN CRITERIA

The Landlord will provide a drywall soffit inside the display windows. The Tenant's ceiling must abut this soffit.

Type 4 signs must be provided by the Tenant; see Section on Retail Signage Criteria. To ensure a high standard of presentation by each Tenant, and necessary continuity of base building design, the Landlord has located Design Control Areas within the Leased Premises. The Design Control Area is the area within the Leased Premise that adjoins the common area of the project and/or affects appearance of the building.

Particular attention shall be given by the Tenant to the visual organization of the Design Control Area as well as the rear and side walls of the sales area. Graphics, signs, materials, colors, finishes and lighting shall all be submitted for approval. **ALL AREAS EXPOSED TO PUBLIC VIEW ARE MUST BE SUBJECT TO APPROVAL BY THE LANDLORD.**

Any penetration or alteration of materials installed or prescribed by the Landlord in this area is not allowed.

Demising piers at the Lease Line and within the Design Control Area are finished by the Landlord. Any attachments to these piers are not allowed. Columns within the Tenant premises but not within the Design Control Area will be finished by the Tenant. The Tenant is advised that certain fixed base building electrical and mechanical services passing through the Leased Premises have been established.



The Tenant must accommodate these components within the design and ensure that appropriate access is provided.

# SECTION 8 – RETAIL SIGNAGE CRITERIA

## 8.0 RETAIL SIGNAGE CRITERIA

### 8.1.1 – Signage Criteria

- All Retail Signage must align with “current industry standards” for signage. All proposed signage designs shall be submitted to the Landlord for preliminary and final Shop Drawing review.

### 8.1.2 – Industry Sign Standards

- Current industry standards include, but are not limited to:
- Illuminated channel letters;
- Illuminated sign box with push through Plexi lettering;
- Metal face metal return;
- Plastic face plastic return; and
- Plastic face and metal return.

### 8.1.3 – Food Court Specific Signage

Food Court specific tenants must refer to “Food Tenant Design Criteria” for signage specifics



# APPENDIX I

## Telecommunication Standards – Commerce Court

### **Purpose**

Commerce Court has asked RYCOM TPM to develop a set of telecommunication cabling standards for their properties. RYCOM TPM has prepared this document that will provide Telco Providers, Tenants and the landlord with the requirements and expectations that Commerce Court has determined are minimum requirements.

### **Codes, Standards & Guidelines.**

All telecommunication work performed within Commerce Court must conform to [ANSI/TIA/EIA](#) telecommunication cabling standards, Ontario Electrical Code (OEC) , [National Fire Protection Association](#) (NFPA) and [Occupational Safety and Health Administration](#) (OSHA). In addition to these codes and standards, contractors must use industry best practices as published by [BICSI](#) and follow the most current release of the [Telecommunication Distribution Methods Manual](#).

Although not mandatory, it's recommended that the designer who is putting together the designs of the telecommunication infrastructure is a BICSI certified RCDD and in good standing. Should the designer not have an RCDD a minimum requirement of 5 years of design experience is needed in order to design and submit drawings to Commerce Court.

Outside Plant work which details conduits and telecommunication cabling outside of the building is the responsibility of the Telco Provider to design, engineer, and obtain permits for. Final Entrance Facility location should be reviewed and approved by Commerce Court. The contractor designing the work shall provide all drawings over to Commerce Court for comment and review. RYCOM TPM will review the drawings and provide onsite project management which will be at RYCOM TPM's current billable rate.

### **Acceptable Communication Cabling and Networking Contractors**

RYCOM TPM

6201 Highway #7

Vaughan, Ontario

1-877-792-6687

[customercare@rycom.ca](mailto:customercare@rycom.ca)



# RYCOM TPM

## 1.0 Pathways

Pathways are spaces that allow telecommunication cabling to run from a source to a destination location. These spaces consist of conduit and sleeves. Pathways can be installed through parking levels, concourse levels, lobbies, riser rooms, and common areas. Listed below are the specific requirements for pathways within the Commerce Court:

- 1.1 Telecommunication cabling shall be installed within conduit located within the parking garages, concourse levels, and common areas extending from the riser room to a tenant suite. Cabling is permitted to be run free air within the riser space provided that best industry practices are followed and the installation conforms to section 2.0 Cabling. It should be noted that any damage done to a cable running free air within the property shall be the responsibility of the owner to fix and replace. Commerce Court will not be held responsible for any damages done or revenues lost.
- 1.2 Should the Tenant or Telco provider want to install conduit within the riser it should be reviewed and approved by the onsite riser manager RYCOM TPM. It is recommended that the conduit is sized for the expected growth and not just the smallest or largest sized conduit installed.
- 1.3 Conduits, connectors, couplers, pull boxes, and covers that are located in the parking garage area and throughout other common visible areas must be painted powder coat white. This must be done offsite, and no other form of paint will be accepted.
- 1.4 When conduits are running horizontal, labels shall be placed approx. every 15 linear feet. (examples would be through the parking garage area)
- 1.5 Conduits and cabling must be labeled on both sides of each wall, floor penetration, and at both ends of a termination point.
- 1.6 Conduits running vertically in the riser system shall be labeled near the top, in the middle at eye level and one near the bottom close to the core hole. This label will provide a means of quick and accurate identification.
- 1.7 Labels shall clearly identify the ownership of the conduit. Commerce Court recommends that additional items such as source and destination locations as well as a contact phone number are included.
- 1.8 Any pre-existing conduits that are not currently labeled and have a single ownership should be labeled with the company who owns the pathway. (Common pathways with multiple ownerships do not need to be labeled.)





- 1.9 Any type of x-raying, scanning, or coring must have a permit which is assigned by the Commerce Court project management team. All concrete structures require x-raying which will be reviewed and approved by Commerce Court's Structural Engineer prior to any core drilling taking place. No cutting of the structural steel and/or rebar shall be permitted or tolerated. Please refer to section 3.17 of the LIM for additional information on Drilling, Coring and X-raying.
- 1.10 **It's the contractor's responsibility to insure that all vertical and horizontal holes their pathway and/or cabling passes through is correctly firestopped.**
- 1.11 Where the cabling enters into a conduit or connector it's the contractor's responsibility to provide firestopping of the conduit as well as the hole the conduit passes through the fire rated wall.

## 2.0 Cabling

Telecommunication cabling allows a service to be transported from a source to a destination location. These cables primarily come in copper and fibre and can be shielded or unshielded with different fire ratings.

- 2.1 All telecommunication cabling running free air within a plenum or non-plenum space shall have a minimum fire rating of FT6. This includes both tenant and riser space. Cabling that is routed within conduit for the entire length can have a minimum fire rating of FT4.
- 2.2 Telecommunication cabling entering from the street and into the building is typically unlisted cabling. There are (2) statements that Telco providers must meet in order to route there unlisted cabling from the point of entry to their POP facilities.
  - 2.2.1 If the entry point (source location) of the unlisted cabling is located within the same room as the destination location, the unlisted cabling can be free aired over to the destination without the need for conduit provided that the room is sealed off and has a minimum 1 hour fire rating.
  - 2.2.2 If the entry point (source location) of the unlisted cabling is located in a different room or the room is not sealed and / or doesn't contain a minimum 1 hour fire rating the Telco Provider is allowed by the Ontario building code to only have 3 meters of exposed unlisted cabling installed. The cabling can be extended to the destination location provided that the unlisted cabling is completely encased within conduit or a splice can is installed to transition from unlisted to a minimum FT6 fire rated cable.
- 2.3 Telecommunication cabling servicing rooftop antennas or devices located external to the building shall be Outside Plant Rated (OSP). If the OSP cable has an FT4 or lower fire rating it shall be encased within conduit for the entire length.
- 2.4 Copper cabling or conductive cabling entering the building from the outside shall be bonded to ground and copper pair cabling shall contain a surge protector. All dielectric non-conductive cabling does not require surge protection or bonding.
- 2.5 Shielded cabling should be bonded to ground.

### 3.0 Spaces

Spaces are places where telecommunication gear is located. This gear can include accumulation panels, passive equipment, active equipment, Telco gear, tenant telecommunication rooms or tenant gear.

- 3.1 No active components requiring electrical power shall be permitted to be installed within the riser rooms. These spaces are meant to be common, and are to house equipment and components that serve base building systems and deliver Telco services to the tenants.
- 3.2 Tenants will only be permitted to install demarcation extension cables inside riser rooms or to gain access to the cellular floor system. Under no circumstances shall the tenant be permitted to install or terminate any station cabling within these riser rooms or place active gear.
- 3.3 Telco providers are permitted to set up Point-Of-Presence (POP) spaces within Commerce Court. These spaces require design drawings from an engineering firm. Telco Providers that are setting up these spaces are required to contact the base building riser manager, RYCOM TPM, to perform site review services. These site review services are billable back to the Telco provider at RYCOM TPM's current rates.
- 3.4 Consultants and designers are required to obtain the services of RYCOM TPM any time a piece of hardware is to be installed or mounted within the riser room. RYCOM TPM will provide written documentation notifying of our recommendations and find and assign the correct amount of space required. These site review services are billable at RYCOM TPM's current rates.

## 4.0 Management and Review

Commerce Court requires that a contractor must contact RYCOM TPM Customer Care and have an access ticket issued to them any time they need access to a riser room.

- 4.1 The contractor's first point of contact for riser room access is RYCOM TPM Customer Care, who will issue the contractor an access ticket. RYCOM TPM Customer Care requires that the contractor provides them with the following:
  - 4.1.1 Start and end dates
  - 4.1.2 Who the Tenant, Telco and General Contractor are
  - 4.1.3 Where they need access
  - 4.1.4 A detailed scope of work stating the following:
    - 4.1.4.1 Who they are doing the work for (i.e. Tenant, General Contractor)
    - 4.1.4.2 Why they need access to the riser
    - 4.1.4.3 What they are doing in the riser room
    - 4.1.4.4 **EXAMPLE.** ABC Contractor is requesting access to 77 RYCOM Street West 34<sup>th</sup> floor riser room to do work on behalf of XYZ General Contractors on the following date. ABC Contractor requires access to provide (1) additional multimode FT6 fibre cable from the 30<sup>th</sup> floor tenant space to the 34<sup>th</sup> floor tenant space VIA the riser in an existing EMT Conduit belonging to the tenant. ABC Contractor will ensure that all firestopping and smoke seals are replaced.
- 4.2 Any installations passing vertically through more than (4) floors require a set of drawings that will be reviewed and approved by the riser manager, RYCOM TPM, prior to any work being conducted.
- 4.3 Cabling installations requiring site reviews will be inspected by RYCOM TPM and are billable at RYCOM TPM's current rates.
- 4.4 In addition to the codes and standards listed within this document, the Telco Agreements and tenant agreements signed are in effect and form part of this document.

## 5.0 Abandoned Cabling & Equipment

Abandoned cabling and equipment are items that are located within the building that are non-active, not plugged in, or cabling that has been left cut and non-active. As per the National Fire Protection Association (NFPA) any of these items listed above are deemed to be abandoned and must be removed.

- 5.1 Telco Providers are to enforce an active role in removing as much of their abandoned infrastructure as possible. (Examples of this would be abandoned equipment, cabinets, cabling and conduits.)
- 5.2 Tenants are to remove their abandoned backbone and horizontal cabling back to the nearest active source when their backbone cabling is no longer required.
- 5.3 No spare coils of horizontal cabling that are owned by the tenant are permitted to be left within the riser rooms. All spare cabling is to be coiled back and left in the tenant's space.
- 5.4 During a Back-To-Base Project, the tenant's project manager and consulting firm are to review the Commerce Court Back-To-Base Clause.
- 5.5 All tenant installed conduit is to be removed back to the nearest active source except for conduit ties from the riser to the tenant space.



# RYCOM TPM

## 6.0 Safety Requirements

At a minimum, all personnel that will be performing work within Commerce Court Riser Rooms must be current with WHMIS training and any technicians performing work on a ladder, scaffold, or other aerial device within the building must also have current Fall Arrest training. The legislation within the Ontario Health and Safety Act (OHSA) must also be adhered to at all times.

- 6.1 All competent workers prior to entering into a space which has the potential to be classed as a confined space must insure that the confined space hazard assessment and control program is implemented. There are many other steps to be taken before any competent workers can enter into a space that has been classified as a confined space and it will be the responsibility of those competent workers who will be entering the confined space to see that the appropriate safety measures have been implemented.
- 6.2 Many injuries result from poor housekeeping. To insure a clean and hazard free workplace, all contractors must implement a daily cleanup program. Contractors will be responsible for removing their waste from site at the end of every working day. Materials and equipment are to always be stored neatly and in such a way that it does not in any way pose a hazard to personnel within the building.
- 6.3 All contractors must wear Personal Protective Equipment (PPE) as necessary to protect the worker against the hazards to which the worker may be exposed.



# APPENDIX II

# Contractor Asbestos Information Package







This package is intended to be reviewed by Contractors performing work at Commerce Court to be aware of the presence and location of asbestos containing materials on site. Contractors are required to review all sections of this package. Contractors are required to sign Form 3 of this package and return to the Project Manager. The contents are as follows.

- Disclaimer
- Contact List
- Contractor Notification (Form 3)
- Work Area Specific Asbestos Inventory and Plans
- Record of Asbestos Work (Form 2)
- Emergency Response Notification and Procedural Flow Chart

## **DISCLAIMER AND LIMITATION OF LIABILITY**

The information contained in this Information Package is intended for general use and may not be applicable to every circumstance. It is not a complete guide to regulatory and legal requirements and does not relieve persons who use this information from their responsibilities under applicable legislation, laws and industry accepted guidelines, standards and practices. Opinions, conclusions and directions expressed in this Information Package should not be construed as legal advice.

QuadReal Property Group do not guarantee the accuracy of the information contained herein and assume no liability for any losses, costs or injuries that may occur as a result of reliance on the information. Any use made by the recipient of this information is the sole responsibility of the recipient.

**CONTACT LIST**

<b><i>Site Contact List</i></b>		
<b>Title/Role</b>	<b>Contact Name</b>	<b>Number</b>
<b>Director, Office East</b>	Sarah Clarke	Phone: 416-366-5286 Cell: 647-408-4434
<b>Property Manager</b>	Taryn Kelly	Phone: 416-572-8594 Cell: 647-215-4931
<b>Environmental Consultant</b>	Pinchin Ltd.	Phone: 855-746-2446
<b>General Manager, Construction Services</b>	Milla Karkas	Phone: 416-364-4976 Cell: 647-988-4976

**Security (non-emergency) - 416-364-6366**

**Security (emergency line) - 416-364-2050**

**Tenant Services Hotline- 1-877- 977-2262**



### CONTRACTOR NOTIFICATION /WORK PERMIT – FORM 3

**A copy of this Permit must be posted at the entrance to any work area where asbestos-containing building materials are known to exist or may exist.**

*Please be advised that QuadReal Property Group has identified the presence of asbestos-containing materials within the property. A baseline asbestos survey report showing the locations and types of asbestos present is available for review from the Property Management/Construction Services Representative.*

**Date:** [Click here to enter text.](#)

**Project Name and/or Work Area:**

---

---

**Name(s) of Contractor, and any Sub-Contractor:**

---

---

---

**Area is known to contain asbestos-containing materials (Yes/No)? If Yes, describe and see below.**

---

---

---

The attached drawings/plans/specifications show the area and indicate the locations of examined materials and whether the materials are friable or not. In the event that a contractor discovers material that may be asbestos-containing material, the following steps shall be taken:

1. The contractor shall stop work and immediately notify (orally and in writing) the Property Management/Construction Services representative; and,
2. Work shall cease until the AMP Program Manager, with assistance from the Corporate Environmental Services Group, as required, has determined whether the material is an asbestos-containing material or not, and the appropriate steps to remediate have been completed, if necessary.

Contractors should ensure their workers, as a minimum, are provided with asbestos awareness training. Proof of this training should be presented to the Property Management/Construction Services Representative, before commencing work at a site.

Workers oriented to onsite conditions **Yes / No**

**Name of Contractor Representative:** [Click here to enter text.](#) \_\_\_\_\_  
(Contractor Signature)

**Permission to start work has been granted by:**

**Name of Property Management/Construction Services Representative:**  
\_\_\_\_\_  
(Authorization Signature)



Insert Work Area Specific Asbestos Inventory and Plans



**RECORD OF ASBESTOS WORK – FORM 2**

**Site:** \_\_\_\_\_

**Location and Description of Work Area:** \_\_\_\_\_

**Commencement Date of Abatement Activities:** \_\_\_\_\_

**Completion Date of Abatement Activities:** \_\_\_\_\_

**Name(s) and Contact Number of Abatement Contractor and Any Sub-Contractor:**

\_\_\_\_\_

**Name(s) and Contact Number of Health & Safety Consultant:**

\_\_\_\_\_  
\_\_\_\_\_

**Scope of Abatement Activities**

Describe the exact location and description of materials enclosed, encapsulated or removed. Attach site drawings, photographs and other information as required to assist with defining the area abated. Include the results of air monitoring and field report as provided by the Approved Consultant.

\_\_\_\_\_  
\_\_\_\_\_  
\_\_\_\_\_  
\_\_\_\_\_  
\_\_\_\_\_  
\_\_\_\_\_

**Name of Property Manager/ Building Operator:**

\_\_\_\_\_

\* Please forward a copy to building's AMP Program Manager. AMP Program Manager will forward a copy to the EHS Data Management Firm and QuadReal's Corporate Environmental Services Group.

END.

## Emergency Response Notification and Procedural Flow Chart (Refer to Section 8.3)

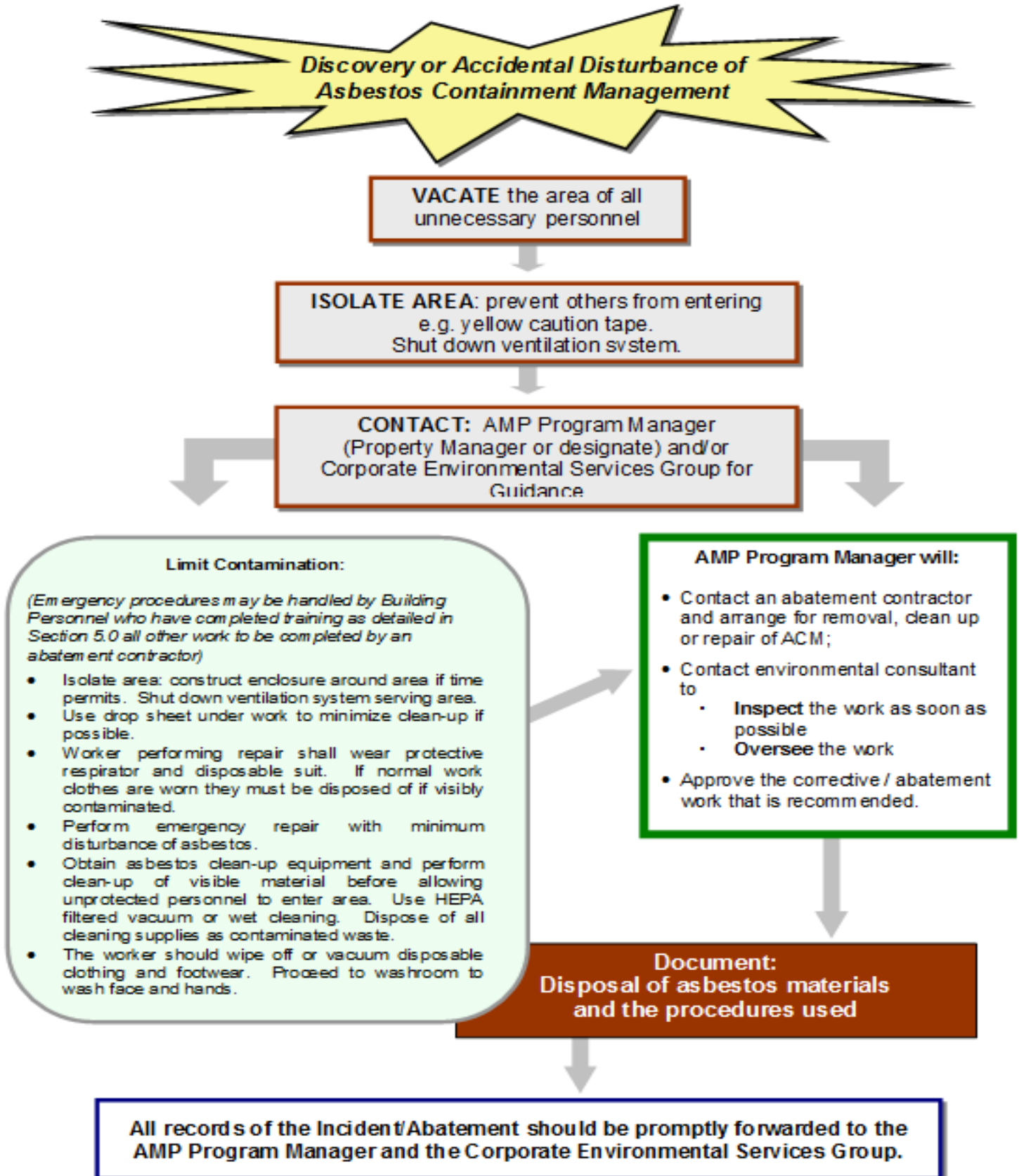



# APPENDIX III





### CONTRACTOR NOTIFICATION /WORK PERMIT – FORM 3

**A copy of this Permit must be posted at the entrance to any work area where asbestos-containing building materials are known to exist or may exist.**

Please be advised that QuadReal Property Group has identified the presence of asbestos-containing materials within the property. A baseline asbestos survey report showing the locations and types of asbestos present is available for review from the Property Management/Construction Services Representative.

**Date:** [Click here to enter text.](#)

**Project Name and/or Work Area:**

---

---

**Name(s) of Contractor, and any Sub-Contractor:**

---

---

---

**Area is known to contain asbestos-containing materials (Yes/No)? If Yes, describe and see below.**

---

---

---

The attached drawings/plans/specifications show the area and indicate the locations of examined materials and whether the materials are friable or not. In the event that a contractor discovers material that may be asbestos-containing material, the following steps shall be taken:

1. The contractor shall stop work and immediately notify (orally and in writing) the Property Management/Construction Services representative; and,
2. Work shall cease until the AMP Program Manager, with assistance from the Corporate Environmental Services Group, as required, has determined whether the material is an asbestos-containing material or not, and the appropriate steps to remediate have been completed, if necessary.

Contractors should ensure their workers, as a minimum, are provided with asbestos awareness training. Proof of this training should be presented to the Property Management/Construction Services Representative, before commencing work at a site.

Workers oriented to onsite conditions **Yes / No**

**Name of Contractor Representative:** [Click here to enter text.](#) \_\_\_\_\_  
(Contractor Signature)

**Permission to start work has been granted by:**

**Name of Property Management/Construction Services Representative:**  
\_\_\_\_\_  
(Authorization Signature)



# APPENDIX IV

FORM 3  
NOTICE TO CONTRACTOR UNDER SUBSECTION 19 (1) OF THE ACT

*Construction Lien Act*

TO: ....., contractor.

FROM: .....,

the landlord of: .....  
(give address of premises)

The landlord of the premises assumes no responsibility for the improvement to be made by you under a contract dated .....  
between you and ..... , a tenant.  
(name of tenant)

Date: .....  
(landlord or agent)

R.R.O. 1990, Reg. 175, Form 3.



# APPENDIX V



June 30, 2017

bclMC Realty Corporation c/o QuadReal Property Group  
199 Bay Street, Suite 1910  
Toronto, Ontario M5L 1E2

Attention: Property Manager

**Re: Duct Modification – Varied Procedures**

Commerce Court Complex  
199 Bay Street, Toronto

**1.0 INTRODUCTION**

Pinchin Ltd. (Pinchin) is pleased to provide the following recommendations regarding the modification or cleaning of ducts within Commerce Court Complex located at 199 Bay Street in Toronto, Ontario.

Pinchin was retained by bclMC Realty Corporation c/o Quadreal Property Group (Client) to prepare varied Type 3 work procedures for modification of ducts throughout the building as per our report entitled “Duct Modification - Varied Procedures, Commerce Court West” dated November 5, 2012. These varied procedures were created using Section 23 of Ontario Regulation 278/05 where we provided proof of equivalent protection procedures for the workers. Findings of this report indicate non-asbestos dust in ductwork. Although no asbestos was detected in the ductwork, procedures are to be followed as per recent Ministry of Labour interpretation of Regulation 278/05.

Duct Modification includes the following:

1. Removal of diffusers, VAV boxes, sections of rigid duct work, etc.
2. Moving of diffusers from one location to another
3. Cleaning dust and debris from within ducts
4. Cutting existing ducts to accommodate the installation of new flex or branch ducting.

Based on our findings the following procedures should be used when duct modifications are planned within an area of the building where original ducts have been replaced during asbestos-abatement projects in past years:

1. Notify the Joint Health and Safety Committee in writing of the use of varied procedures



2. Notify workers that they are modifying, removing, cleaning, etc. ducts in a building with asbestos-sprayed fireproofing (ducts on this floor are non-asbestos containing).
3. Workers are to be trained on this specific set of procedures and have asbestos awareness training.
  - a. Workers do not need to be trained in Type 3 Worker Training.
4. Shut down HVAC system being worked on.
5. Install drop sheets below areas of work (drop sheets can be disposed of as non-asbestos waste).
6. Disposable suits and respirators (P100 filters) must be made available to the workers. Suits and respirators are optional PPE for this work and therefore not required.
  - a. If worker requests the use of suit and/or respirator the worker is to be fit tested for the respirator and wear both the suit and respirator during planned modifications.
7. The use of power tools is strictly prohibited.
  - a. Tools to be used during duct modifications are restricted to power shears, battery assisted screwdrivers and hand tools (including hammers).
  - b. Tools not to be used include; hole saws, reciprocating saws and grinders.
  - c. Should other tools be needed to perform work, please contact environmental consultant for guidance.
8. Ductwork removed for disposal can be disposed of as clean waste.

## **2.0 LIMITATIONS**

The work performed by Pinchin Ltd. was conducted in accordance with the Master Service Agreement between Client and the Pinchin Group of Companies, dated March 1, 2017. The document was prepared by Consultant for the use of Owner and Manager (as those terms are defined under the MSA). In addition to the use of and reliance on this document by Owner and Manager, any person who has received a reliance letter for this document may use and rely on this document as if it was prepared for such persons. Any use of or reliance on this document by any other person (i.e., a person other than any Owner, Manager or otherwise permitted person) is the sole and exclusive responsibility of such other person. Consultant accepts no responsibility for damages, if any, suffered by such other person as a result of the use of or reliance on this document.

This document is based on the best information available to the Consultant at the time of preparing this document after Consultant used best industry practices, in the circumstances, to obtain information. To



the extent that Consultant was required to reply on information from other persons, Consultant has verified such information to the extent reasonably possible in the circumstances. The material provided in this document reflects best industry judgment in light of the information available at the time of preparation of this document.

### **3.0 CLOSURE**

Should you have any questions or concerns regarding the contents of this letter, please contact Alex Brett at (905) 363-1343.

Yours truly,

**Pinchin Ltd.**



# APPENDIX VI





June 30, 2017

bclMC Realty Corporation c/o QuadReal Property Group  
199 Bay Street, Suite 1910  
Toronto, Ontario M5L 1E2

Attention: Property Manager

**Re: Cable Pulling and Conduit Installation**  
General Procedures - Commerce Court Complex

Pinchin Ltd. (Pinchin) was retained by British Columbia Investment Management Corporation (bclMC) and bclMC Realty Corporation c/o Quadreal Property Group (Client) to provide the following standard scope of work when the installation of conduit or cables is required at Commerce Court Complex, located in Toronto, Ontario.

Based on our knowledge of work required from time to time at Commerce Court, there is work that may disturb existing asbestos-containing materials (ACM) within the Tower. The ACM most likely to be disturbed during the installation of conduit or cables is drywall joint compound, and/or original sprayed fireproofing as well as vinyl asbestos floor tiles and fire stopping in the Riser Rooms.

In order to facilitate this work the following procedures are required as per Ontario regulation 278/05.:

## 1.0 PROCEDURES

### **Cable or Conduit Installation above Ceilings where Original Sprayed Fireproofing Exists**

Work within a ceiling space where original sprayed fireproofing is present is to be performed following Type 2 Procedures as follows:

1. Prior to accessing the ceiling space, place a drop sheet below area of access. Access area should be cordoned off using barrier tape warning of the potential of an asbestos hazard.
2. Workers accessing the ceiling space are to wear suits and respirators.
  - a. If significant sprayed fireproofing debris is present on the top side of the ceiling tiles, a Type 2 Enclosure is to be constructed around the access point.
  - b. Workers are to be fit tested for their respirator and be trained in the use and care of the respirator.
3. Pull cables or install conduit avoiding disturbance of sprayed fireproofing on the structure.



- a. If sprayed fireproofing is to be disturbed or is accidentally disturbed, stop work and consult the Owner for guidance.
4. Upon completion of work above the ceiling, replace ceiling tile, wet wipe and/or HEPA vacuum the drop sheet and dispose of as asbestos waste.
5. Air monitoring below the area of work can be performed to ensure the occupied air borne fibre levels are acceptable prior to re-occupancy. It should be noted that air monitoring in this case is not required by Regulation 278/05.

### **Cable Pulling Within Core Walls or Column Enclosures**

This type of work can occur within one floor or span from floor to floor. Where work is to occur within one floor the following procedures are required.

1. Cut access holes in drywall walls or column enclosures no larger than 1 square meter following Type 1 procedures using hand tools.
  - a. Suits and respirators are optional for this work.
2. Run cables from source to core wall or column enclosure as required.
  - a. This work may require the use of the above noted Type 2 procedures if the floor remains sprayed with original sprayed fireproofing.
3. If sprayed fireproofing is present on columns or as overspray in core walls and is disturbed during the planned work, stop work immediately and follow Type 2 procedures for all remaining work required.
  - a. Type 2 procedures will require the use of a drop sheet below access holes and the worker will be required to wear a suit and respirator.

Where work will span from floor to floor within column enclosures, pipe chases, etc where asbestos-containing sprayed fireproofing is known to be present the following procedures are to be utilized:

1. Drop sheets are to be placed below all access hatches or holes created. Workers should wear suits and respirators.
  - a. Holes created in drywall are to be created following Type 1 procedures using hand tools.
2. During the initial cable pulling operation, enlist the services of an Environmental Consultant to conduct air monitoring within the work areas and occupied spaces to confirm that air borne fibre levels are acceptable.
  - a. If air borne fibre levels are found to be acceptable, the workers would no longer be required to wear the suits and respirators although this practice would still be recommended.
  - b. In the event that the Environmental Consultant observes an elevated level of disturbance of ACM, workers will be required to continue to wear suits and respirators to complete the planned work.



3. In the event of asbestos disturbance where debris is created, stop all work and perform a Type 2 clean up of the affected areas. Air Monitoring should be performed prior to resuming planned work.

### **Cable Pulling and Conduit Installation in Riser Rooms**

The installation of conduit and/or cables within Riser Rooms may disturb asbestos and therefore the following Type 2 procedures are to be utilized:

1. Prior to the start of any work, view condition of Riser Rooms above and below area of work for asbestos-containing materials that may be disturbed during the installation process.
2. When using existing conduit sleeves, avoid penetrating sleeves filled with any material other than fibreglass or caulking.
  - a. Investigate below caulking by cutting caulking to view condition within sleeve prior to installation of cables and/or conduit.
  - b. Using existing fibreglass filled sleeves will not require any asbestos precautions.
3. If existing sleeves insulated with asbestos-containing firestopping material are to be used, remove firestopping material following Type 2 asbestos procedures. The Type 2 procedures required include but are not limited to the following:
  - a. Enclosure to be constructed in Riser Room below sleeve to be cleaned.
  - b. Workers to wear suits and respirators during removal process.
  - c. Water is to be used to wet materials prior to removal. Avoid excessive water or any water at all if it will create an electrical hazard.
4. If new floor penetrations are to be created to accommodate the installation of cables and/or conduit the following procedures are to be utilized:
  - a. Review condition of floor and deck to ensure asbestos-containing floor tiles and/or sprayed fireproofing will not be disturbed by the core drilling operation.
  - b. If vinyl floor tiles will be disturbed, remove affected flooring following Type 1 procedures. Only hand tools can be used to remove vinyl floor tile. Vinyl floor tiles to be misted with water prior to removal process.
    - i. Suits and respirators are optional for workers.
    - ii. The Owner will provide asbestos waste bags and HEPA vacuums to perform removal.
  - c. If sprayed fireproofing will be disturbed, removal of the spray will require Type 2 procedures and should be completed by an Asbestos Abatement Consultant.

If conduit is to be installed against drywall walls within the Riser Room, Type 1 Procedures are required as follows:

1. Install conduit clips using hand tools only. Hand held tools include the use of a power assisted cordless screwdriver or less.



2. Prior to the installation of the conduit clip, mist area behind and around installation point.
3. If drywall joint compound is disturbed, stop work immediately and contact the Owner for guidance.

If any condition not identified above is observed prior to the start of work, consult the Owner for Guidance.

## **2.0 LIMITATIONS**

The work performed by Pinchin Ltd. was conducted in accordance with the Master Service Agreement between Client and the Pinchin Group of Companies, dated March 1, 2017. The document was prepared by Consultant for the use of Owner and Manager (as those terms are defined under the MSA). In addition to the use of and reliance on this document by Owner and Manager, any person who has received a reliance letter for this document may use and rely on this document as if it was prepared for such persons. Any use of or reliance on this document by any other person (i.e., a person other than any Owner, Manager or otherwise permitted person) is the sole and exclusive responsibility of such other person. Consultant accepts no responsibility for damages, if any, suffered by such other person as a result of the use of or reliance on this document.

This document is based on the best information available to the Consultant at the time of preparing this document after Consultant used best industry practices, in the circumstances, to obtain information. To the extent that Consultant was required to rely on information from other persons, Consultant has verified such information to the extent reasonably possible in the circumstances. The material provided in this document reflects best industry judgment in light of the information available at the time of preparation of this document.

## **3.0 CLOSURE**

Should you have any questions or concerns regarding the contents of this letter, please contact Alex Brett at (905) 363-1343.

Yours truly,

**Pinchin Ltd.**



# APPENDIX VII



June 30, 2017

bclMC Realty Corporation c/o QuadReal Property Group  
199 Bay Street, Suite 1910  
Toronto, Ontario M5L 1E2

Attention: Property Manager

**Re: Working Around Asbestos-Containing Joint Compound**  
Commerce Court Complex

Pinchin Ltd. (Pinchin) was retained by bclMC Realty Corporation c/o Quadreal Property Group to provide an instruction document for working around asbestos-containing joint compound present on core and perimeter walls and columns within Floors of the Commerce Court Complex.

The following work may be performed within vacant tenant spaces.

1. Removal of vinyl wallpaper.
2. Removal of vinyl or carpet base boards.
3. Repair and skim coat walls as necessary to provide a smooth finish.
4. Apply new finishes (paint, wallpaper, etc.) to walls.
5. Install steel stud partitions against existing drywall walls finished with asbestos-containing drywall joint compound.
6. Removal of less than 1 square metre of drywall.
7. Repair of void in drywall.

The following procedures should be followed during the above noted work.

## 1.0 PROCEDURES

### Removal of vinyl wallpaper

1. Inform all trades working on walls that the joint compound contains asbestos.
2. Use normal procedures (heat or water) to remove wall paper without disturbance of the drywall joint compound. Removal of wallpaper must stop and procedures revised if drywall joint



compound is disturbed (i.e. stick to wallpaper during removal). Use drop sheets in case of joint compound disturbance and for normal cleanup of wall paper.

3. Apply a coat of primer paint to exposed drywall joint compound at joints and nail/screw locations to indicate the top of the existing drywall joint compound. The prior paint should be a different colour than that of the compound.
4. Apply skim coat material to areas of the wall requiring repair.
5. Sand skim coat with hand tools using the primer paint as a barrier (i.e. stop sanding if primer paint affected by sanding).
6. Apply new finishes as required.

### **Removal of vinyl or carpet base boards**

1. Inform all trades working on walls that the joint compound contains asbestos.
2. Use normal procedures (heat or water) to remove base boards without disturbance of the drywall joint compound. Removal of base boards must stop and procedures revised if drywall joint compound is disturbed (i.e. sticks to base boards during removal). Use drop sheets in case of joint compound disturbance.
3. Apply a coat of primer paint to exposed drywall joint compound at joints and nail/screw locations to indicate the top of the existing drywall joint compound. The prior paint should be a different colour than that of the compound.
4. Apply skim coat material to areas of the wall requiring repair.
5. Sand skim coat with hand tools using the primer paint as a barrier (i.e. stop sanding if primer paint affected by sanding).
6. Apply new finishes as required.

### **Installation of Stud Wall**

1. Inform all trades working on walls that the drywall joint compound contains asbestos.
2. Install panels on existing drywall wall using either hand tools or a power assisted cordless screw driver. Fasten to the core wall away from joints where asbestos-containing joint compound exists.
3. If existing drywall joint compound is disturbed, stop work immediately and contact Owner for guidance regarding continuation of work.



4. No asbestos precautions are required.

### **Repair, Finishing or Skim Coat of Walls**

1. Inform sub-trades that the drywall joint compound contains asbestos.
2. Apply new joint compound as required to skim coat or finish existing drywall.
3. Sand skim coat or finish application with hand tools using the existing paint as a barrier (i.e. stop sanding if paint affected by sanding).
4. Apply new wall finishes as required.
5. No asbestos precautions are required.

### **Removal of less than 1 square metre of drywall**

1. Inform all trades working on walls that the drywall joint compound contains asbestos.
2. Protect drywall around areas to be removed by covering with polyethylene and taping seams to wall.
3. Mist surface of drywall and drywall joint compound.
4. Cut drywall and remove using non-powered hand-held tools. Place directly into a 6 mil polyethylene bag.
5. HEPA vacuum floor.

### **Repair of Void in Drywall**

1. Inform all trades working on walls that the drywall joint compound contains asbestos.
2. Use Type 1 asbestos abatement procedures to remove drywall back to stud to create clean square opening.
3. Install drywall in the wall or column where the cleaned void exists. No asbestos precautions are required.
4. Refer to the Repair, Finishing or Skim Coat of Walls section for steps in order to finish the wall and make good.

## **2.0 DISCUSSION**

Since there is no disturbance of the existing drywall joint compound the above listed procedures are not considered a regulated asbestos procedure and hence this work can be done by your normal trade contractor (no specific asbestos training or government notice required). It is important that the workers





be notified, in some documented fashion, that the existing drywall joint compound does contain asbestos and that they should not disturb this material during their work. If there is any concern expressed by the workers, the contractor, or your tenants, it may be useful to have some air monitoring performed on the initial work following these procedures and to keep this report for record (the air monitoring would not be needed on future projects).

### **3.0 LIMITATIONS**

The work performed by Pinchin Ltd. was conducted in accordance with the Master Service Agreement between Client and the Pinchin Group of Companies, dated March 1, 2017. The document was prepared by Consultant for the use of Owner and Manager (as those terms are defined under the MSA). In addition to the use of and reliance on this document by Owner and Manager, any person who has received a reliance letter for this document may use and rely on this document as if it was prepared for such persons. Any use of or reliance on this document by any other person (i.e., a person other than any Owner, Manager or otherwise permitted person) is the sole and exclusive responsibility of such other person. Consultant accepts no responsibility for damages, if any, suffered by such other person as a result of the use of or reliance on this document.

This document is based on the best information available to the Consultant at the time of preparing this document after Consultant used best industry practices, in the circumstances, to obtain information. To the extent that Consultant was required to rely on information from other persons, Consultant has verified such information to the extent reasonably possible in the circumstances. The material provided in this document reflects best industry judgment in light of the information available at the time of preparation of this document.

### **4.0 CLOSURE**

Should you have any questions or concerns regarding the contents of this letter, please contact Alex Brett at (905) 363-1343.

Yours truly,

**Pinchin Ltd.**



# APPENDIX VIII

# APPENDIX VIII

## CLASSIFICATION OF ASBESTOS WORK - ONTARIO REGULATION R.R.O. 278/05

Material	Disturbance	Extent	Classification
<b>Nonfriable</b>	Hand Held Non-Powered	Not Broken	TYPE 1
Transite	Hand Held Non-Powered Dry	Any Amount	TYPE 2
Packing	Power Tools without Effective HEPA Dust Collector	Any Amount	TYPE 3
Gaskets		Any Amount	TYPE 2
Vinyl Floor Tile, Textile	Power Tools with HEPA Dust Collector	Any Amount	TYPE 2
Etc.	Drywall with Asbestos Joint Compound	<1m <sup>2</sup> , >1m <sup>2</sup>	TYPE 1, TYPE 2
<b>ACOUSTIC CEILING TILES</b>	Removal/Replacement	≤10 Tiles	TYPE 1
Lay-in Mineral Wool Type	Removal/Replacement	>10 Tiles	TYPE 2 *
<b>Friable</b>	Entry at Visible Asbestos Debris (Ceiling, Crawlspace, etc.)	Any Amount	TYPE 2 (enclosure)
Sprayed Asbestos	Removal or Disturbance	<1m <sup>2</sup> or equivalent	TYPE 2 (enclosure or glove bag required)
	Removal or Disturbance	>1m <sup>2</sup> or equivalent	TYPE 3 (enclosure or glove bag required)
Acoustic/Texture Plaster	Repair of Mechanical Insulation	Any Amount	TYPE 2 (drop sheet only)
Mechanical Insulation	Spray Encapsulation of Sprayed Asbestos or Acoustic/Stipple Plaster	Any Amount	TYPE 3
Asbestos Plaster (When Disturbed)	Cleaning Or Removal Of Ductwork, AHU Filters In Building With Asbestos Fireproofing	Any Amount	TYPE 2
Sheet Flooring	Repair, Alteration or Demolition of a Kiln, Furnace with Asbestos Refractory	Any Amount	TYPE 3
	Repair, Alteration or Demolition of a Building where Asbestos was Used in Manufacture	Any Amount	TYPE 3

\* Pinchin Recommendation

**General Note:** Ministry of Environment and Energy requirements for packing and hauling asbestos waste apply to Type 1, Type 2, and Type 3 work, i.e. no exemption for any friable material.



# APPENDIX IX



SMILLIE McADAMS SUMMERLIN LTD.

900 McKAY ROAD, UNIT 1, PICKERING, ONTARIO, CANADA L1W 3X8 • Phone: (905) 428-6900 • Fax: (905) 428-6598

## **IDENTIFICATION SYSTEM SPECIFICATION**

Contractor shall provide and install a complete identification system as specified following as manufactured by Smillie McAdams Summerlin Ltd., Pickering, Ontario.

### **PIPE SYSTEMS**

Contractor shall identify all pipe or pipe covering with S.M.S. Coil-Mark. All identification shall incorporate direction of flow arrows, and the manufacturer's standard system designations, or abbreviations. Special system designations and abbreviations to be submitted for approval prior to use. Colour coding to be in conformance with CAN/CGSB-24.3-92 and ANSI A131-1981.

Identification must be applied at intervals not greater than 40 ft., adjacent to valves, behind access doors, at changes in direction and where pipes pass through walls or floors.

All pipe identification shall be installed in accordance with the manufacturer's recommendations.

### **VALVES**

Contractor shall identify all valves by means of an S.M.S. SP-1500 series 1½ " square laminated plastic valve tag. Tags to be colour coded in conformance with piping system colours as per CAN/CGSB-24.3-92. The system code to be 3/16" high characters on the top line, valve numbers to be 3/8" high on the bottom line. Tags to be consecutively numbered and coded as per following schedule.

Note: Special system designator codes to be approved by this consultant prior to tagging. All tags to be secured to valves by a brass bead chain.

Contractor shall provide and mount for owner a typed valve directory in a black document frame, listing complete valve number, location and service. Individual fixture valves need not be identified.

## **EQUIPMENT**

Contractor shall identify all equipment such as, but not limited to fans, pumps, motors, AHU's and their related starters by means of an engraved two-ply plastic I.D. plate.

Equipment I.D. plates shall have  $\frac{3}{8}$ " white characters on black background; starter I.D. plates shall be as above with  $\frac{1}{8}$ " characters. All plates shall be sized to accommodate required description bearing type of equipment, number and service. Locate conspicuously and secure with self tapping sheet metal screws where possible, or double sided adhesive tape. Recognized abbreviations will be acceptable, other proposed abbreviations to be approved by this consultant.

## **DUCTWORK**

Contractor shall identify all Ductwork with 2" stencils using black or white ink to contrast surface being identified.

Identification locations shall conform to guidelines for pipe and shall indicate flow medium, function and direction.

Contractor shall ensure stenciling is performed in a neat, quality manner. Upon completion of project contractor shall turn over one complete set of stencils as used on the project to the building owner.



# Pipe, Valve and Equipment Identification

Smillie McAdams Summerlin Ltd.



# Smillie McAdams Summerlin Ltd.

Smillie McAdams & Summerlin Limited (S.M.S.) has been serving the construction industry as a major supplier of pipe, valve, and equipment identification since 1970.

S.M.S. manufactures a wide range of high quality, competitively priced products with applications in the plumbing, heating, air conditioning and fire protection trades.

To satisfy customer requirements and ensure prompt delivery, S.M.S. maintains significant inventory of Coil-Mark, pipe markers, banding tape, stencil marking equipment and valve tags.

Engraved I.D. plates and stencils are promptly made to order while custom Coil-Mark, pipe markers and valve tags can be special ordered to suit a range of requirements.

## Coil-Mark

### ORDERING CODES

#### Coil-Mark

SIZE	O.D. RANGE	LTR. HT.
012	3/8" - 5/8"	1/4"
025	3/4" - 1 1/4"	1/2"
050	1 1/8" - 2 3/8"	3/4"
100	2 1/2" - 4 1/2"	1 1/4"
150	4" - 6"	1 3/4"
200	6" - 10"	2 1/4"
250	10" - 18"	3 1/2"
500	over 18"	4 1/2"

### ORDERING INSTRUCTIONS

To order Coil-Mark, first give the size, and then model no. Eg: To order Coil-Mark with legend: DOM. COLD WTR. for 3" total O.D. would be: 100-D07. To order bilingual models add BIL as follows: 100-BIL-D07.

### COLOUR LEGEND

B/Y: Black letters / Yellow background  
 W/G: White letters / Green background  
 W/R: White letters / Red background  
 W/B: White letters / Blue background

NOTE: Special order colour combinations available.

### PRODUCT DESCRIPTION

S.M.S. Coil-Mark, our premier system for pipeline identification, provides a highly functional and visually appealing marking system. Facility operators, engineers and contractors will benefit from the specification and installation of this superior cost-effective product. Coil-Mark is stocked in English and available in French or Bilingual formats. Coil-Mark provides the best possible results in pipe identification.

Coil-Mark is manufactured from semi-rigid plastic vinyl, with surface printing using premium quality ultraviolet inks. This provides an indefinite indoor life span and an estimated 5-7 year outdoor life span. For outside diameters up to 6" the markers are coiled and wrap completely around the pipe with six rows of wording in alternating directions. This style of marker provides 360° visibility and legibility for optimum identification. On larger than 6" total O.D. the markers are saddle style with two rows of wording and are installed using 3/4" long nylon cable ties provided with the marker.

### Coil-Mark features:

- Quick, neat installation with minimal labour and professional results
- Effective installation on a variety of surface conditions such as insulated or dirty pipe
- Integral flow arrows and wording in alternating directions
- Enhanced visibility and legibility from various vantage points
- An objective analysis of the "total installed cost" will prove Coil-Mark to be more economical than other systems.





# Schedule 1: Coil-Mark

DESCRIPTION	MODEL	COL.	DESCRIPTION	MODEL	COL.	DESCRIPTION	MODEL	COL.
Acetylene	A01	B/Y	Fire Prot. Water	F03	W/R	Oxygen	O02	W/G
Acid	A02	B/Y	Fire Standpipe	F04	W/R			
Acid Drain	A03	B/Y	Fuel Oil	F07	B/Y	Plant Air	P02	W/G
Argon	A10	W/B	Fuel Oil Return	F08	B/Y	Plumbing Vent	P04	W/G
			Fuel Oil Supply	F09	B/Y	Potable Water	P06	W/G
Boiler Blowdown	B02	B/Y	Fan Coil Drain	F10	W/G	Process Water	P10	B/Y
Boiler Feed Wtr.	B03	B/Y	Fuel Oil Vent	F11	B/Y	Propane Gas	P11	B/Y
Backwash Line	B07	W/G				Pumped Condensate	P14	B/Y
Blow-off	B08	B/Y	Glycol	G03	B/Y	Pure Steam	P15	B/Y
Biohazard Vent	B09	B/Y	Glycol Htg. Sup.	G04	B/Y	Pump. Cond. Ret.	P16	B/Y
Biohazard Waste	B10	B/Y	Glycol Htg. Ret.	G05	B/Y	Pumped Drain	P17	W/G
			Glycol Cool. Ret.	G06	B/Y	Perimeter Htg. Ret.	P18	B/Y
Caustic	C01	B/Y	Glycol Cool. Sup.	G07	B/Y	Perimeter Htg. Sup.	P19	B/Y
Chemical Feed	C02	B/Y	Gravity Condensate	G08	B/Y			
City Water	C06	W/G	Gas Vent	G09	B/Y	Raw Water	R05	W/G
Compressed Air	C09	B/Y	Glycol Make-up	G10	B/Y	Rev. Osmosis Ret.	R13	W/G
Condensate	C11	B/Y				Rev. Osmosis Sup.	R14	W/G
Condensate Ret.	C15	B/Y	Heating Wtr. Ret.	H16	B/Y	Reheat Return	R15	B/Y
Chilled Wtr. Ret.	C16	W/G	Heating Wtr. Sup.	H17	B/Y	Reheat Supply	R16	B/Y
Chilled Wtr. Sup.	C17	W/G	High Press. Steam	H18	B/Y	Refrig. Liquid	R17	B/Y
Condensate Sup.	C18	B/Y	High Press. Cond.	H19	B/Y	Refrig. Suction	R18	B/Y
Cond. Water Ret.	C19	W/G	Humidity Air	H22	W/G	Rev. Osmosis Wtr.	R19	W/G
Cond. Water Sup.	C20	W/G	Heat Pump Return	H23	B/Y	Refrigerant	R20	B/Y
Chemical	C23	B/Y	Heat Pump Supply	H24	B/Y	Refrigerant Gas	R21	B/Y
Carbon Dioxide	C24	B/Y	Heat Reclaim Ret.	H26	B/Y			
Chiller Relief	C25	W/G	Heat Reclaim Sup.	H27	B/Y	Sanitary Drain	S01	W/G
Cooling Tower Ret.	C26	W/G	Heat Pump Drain	H28	W/G	Soap Supply	S06	W/G
Cooling Tower Sup.	C27	W/G	High Press. Nat. Gas.	H29	B/Y	Sprinkler Water	S12	W/R
Compressor Vent	C28	W/G				Steam	S14	B/Y
Clean M.P. Steam	C29	B/Y	Instrument Air	I02	W/G	Storm Drain	S15	W/G
Condensate Drain	C30	B/Y	Isotope Drain	I04	B/Y	Softened Recirc.	S18	B/Y
						Softened Hot	S19	B/Y
Deionized Water	D01	W/G	Lab Air	L02	W/G	Softened Cold	S20	W/G
Distilled Water	D06	W/G	Low Press. Cond.	L07	B/Y	Still Blowdown	S22	B/Y
Dom. Cold Water	D07	W/G	Low Press. Steam	L08	B/Y	Steam Supply	S23	B/Y
Dom. Hot Water	D08	B/Y	Lab Drain	L10	B/Y	Storm Sewer	S25	W/G
Dom. H.W. Recirc.	D09	B/Y	Lab Vent	L11	B/Y	Sanitary Sewer	S26	W/G
Dom. H.W. Recirc.	D09	W/G	Low Press. Gas	L12	B/Y	Steam Vent	S27	B/Y
Drain	D12	W/G	Lab Vacuum	L13	W/G	Softened Water	S28	W/G
Dom. H.W. Supply	D16	W/G	Low Press. Nat. Gas	L14	B/Y	Steril. San. Drain	S29	B/Y
Dealkalized Water	D17	W/G				Sump Pump Drain	S31	W/G
Demineralized Water	D18	W/G	Med. Press. Cond.	M04	B/Y			
District Htg. Ret.	D19	B/Y	Med. Press. Steam	M05	B/Y	Tempered Water	T02	W/G
District Htg. Sup.	D20	B/Y	Mixed Gas	M06	B/Y	Treated Water	T05	W/G
Diesel Fuel	D21	B/Y	Make-up Water	M07	B/Y	Trap Primer	T06	W/G
			Med. Temp. Wtr. Ret.	M08	B/Y			
Exhaust	E02	B/Y	Med. Temp. Wtr. Sup.	M09	B/Y	Vacuum	V01	W/G
Engine Exhaust	E04	B/Y				Vacuum Vent	V04	W/G
			Natural Gas	N01	B/Y			
Fan Coil Return	F01	B/Y	Nitrogen	N02	W/B	Wtr. for Injection	W04	W/B
Fan Coil Supply	F02	B/Y	Non Potable Wtr.	N03	W/G			



## Building Service Pipe Markers

### ORDERING CODES

#### Building Service Pipe Markers

To simplify ordering building service pipe markers, each legend has an alpha-numeric order code. The code number identifies each legend and provides information for estimating and ordering quantity of cards.

IE: Dom. Hot Water D08Y41

DOM. HOT WATER	DOM. HOT WATER
DOM. HOT WATER	DOM. HOT WATER

- D08 = Legend code number
- Y = Background colour
- 4 = Number of legends per card
- 1 = Size of lettering

When ordering, specify quantity of cards and alpha-numeric code number.

NOTE: Typical specifications call for 1" legends on up to 3" total O.D. (includes pipe and/or insulation) for larger O.D.'s use 2" legends.

### PRODUCT DESCRIPTION

S.M.S. building service pipe markers provide durable, accurate, high quality identification of piping systems and are available from stock in English or French.

Markers are 6 mil thick ( $\pm 0.05$  mil) vinyl with a pressure sensitive acrylic adhesive backing. Characters are silk-screened on each marker using vinyl ink. Colour coding conforms to C.G.S.B.-24.3-92 and ANSI A131-1981. Stock pipe marker cards are 2 1/4" high by 14" long with 1" or 2" nominal size letters and incorporate various quantities of legends. Special order sizes from 1/4" to 4" letters are available. Schedule 2 provides information on size, colour, and quantity of standard legends per card.

Recommended installation is for interior use on clean, dry surfaces. For use on dirty, loose or porous surfaces such as insulation; pipe banding tape should be spiral wrapped around the pipe to accommodate the full length of the marker. The marker should then be applied to this prepared surface. After all applications of building service pipe markers, apply a 360° wrap of pipe banding tape on each end of the marker ensuring that the tape overlaps itself several inches.



## Standard & Arrow Banding Tape

### ORDERING CODES

#### Standard Pipe Banding Tape

COLOUR	1"	2"
Yellow	PBT-YEL-1	PBT-YEL-2
Green	PBT-GRE-1	PBT-GRE-2
Red	PBT-RED-1	PBT-RED-2
White	PBT-WHI-1	PBT-WHI-2
Black	PBT-BLA-1	PBT-BLA-2
Orange	PBT-ORA-1	PBT-ORA-2
Blue	PBT-BLU-1	PBT-BLU-2
Brown	PBT-BRO-1	PBT-BRO-2
Grey	PBT-GRY-1	PBT-GRY-2
Purple	PBT-PUR-1	PBT-PUR-2

#### Arrowed Pipe Banding Tape

COLOUR	1"	2"
Yellow	N/A	PBTA-YEL
Green	N/A	PBTA-GRE
Red	N/A	PBTA-RED



### PRODUCT DESCRIPTION

Standard pipe banding tape is 5.5 mil thick vinyl, with a pressure sensitive adhesive backing. Tape is available from stock in a variety of colours in 1" and 2" nominal widths by 36 yard long rolls. Arrowed banding tape is an economical alternative to the use of pipe marker arrows and standard banding tape. Directional arrowed tape is 2" wide by 75 yard long rolls with small arrows appearing continuously.



The common application for banding tape is to permanently secure building service pipe markers and provide a 360° reference band next to markers or stencilled legends. With a variety of 10 colours available, a complete custom, colour coded I.D. system could also be designed.

## Schedule 2: Building Service Pipe Markers

LEGEND	1"	2"	LEGEND	1"	2"	LEGEND	1"	2"
Acetylene	A01Y41	A01Y12	Fresh Air	F06G41	F06G12	Potable Water	P06G41	P06G12
Acid	A02Y41	A02Y22	Fuel Oil	F07G41	F07G22	Potable Water	P07Y41	P07Y12
Acid Drain	A03Y41	A03Y12				Primary	P08G41	P08G12
Acid Waste	A04Y41	A04Y12	Gas	G01Y41	G01Y22	Primary	P09Y41	P09Y12
Air	A05G41	A05G22	Gasoline	G02Y41	G02Y12	Process Water	P10Y41	P10Y12
Air	A06Y41	A06Y22	Glycol	G03Y41	G03Y22	Propane Gas	P11Y41	P11Y12
Arrow 	A07G41	A07G22				Pump Condensate	P12Y41	P12Y12
Arrow 	A08R41	A08R22	HTHW	H01Y41	H01Y22	Pump Discharge	P13Y41	P13Y12
Arrow 	A09Y41	A09Y22	Heat Pump	H02Y41	H02Y12	Pumped Drain	P14G41	P14G12
			Heat Reclaim	H03Y41	H03Y12			
Bearing Cooling Wtr.	B01G21	B01G12	Heating	H04Y41	H04Y12	R.W.L.	R01G41	R01G22
Boiler Blowdown	B02Y21	B02Y12	Heating Return	H05Y41	H05Y12	Radiation Return	R02Y21	R02Y12
Boiler Feed Water	B03Y21	B03Y12	Heating Supply	H06Y41	H06Y12	Radiation Supply	R03Y21	R03Y12
Breathing Air	B04G41	B04G12	Heating Water	H07Y41	H07Y12	Radiation Water	R04Y21	R04Y12
By Pass	B05G41	B05G22	Hi. Pressure	H08G41	H08G12	Raw Water	R05G41	R05G12
Backwash Line	B06G41	B06G12	Hi. Pressure	H09Y41	H09Y12	Recirc.	R06G41	R06G22
			Hi. Press. Cond.	H10Y41	H10Y12	Recirc.	R07Y41	R07Y22
Caustic	C01Y41	C01Y22	Hi. Press. Steam	H11Y41	H11Y12	Refrigeration	R08Y41	R08Y12
Chemical Feed	C02Y41	C02Y12	Hot Water	H12Y41	H12Y12	Reheat Coils	R09Y41	R09Y12
Chilled Water	C03G41	C03G12	Hot Water Heating	H13Y21	H13Y12	Return	R10G41	R10G22
Chlorine	C04Y41	C04Y12	Hot Water Recirc.	H14Y21	H14Y12	Return	R11Y41	R11Y22
Circulating Water	C05G21	C05G12	Hydraulic	H15G41	H15G12	Reverse	R12Y41	R12Y22
City Water	C06G41	C06G12				Reverse Osmosis	R13G41	R13G12
Cold Water	C07G41	C07G12	Industrial	I01G41	I01G12			
Compressed Air	C08G41	C08G12	Instrument Air	I02G41	I02G12	Sanitary Drain	S01G41	S01G12
Compressed Air	C09Y41	C09Y12	Instrument Air	I03Y41	I03Y12	Sea Water	S02G41	S02G12
Condensate	C10G41	C10G12	Isotope Drain	I04Y41	I04Y12	Service Air	S03G41	S03G12
Condensate	C11Y41	C11Y12				Siamese	S04R41	S04R12
Condenser Water	C12G21	C12G12	___KPA	K01Y41	K01Y22	Skimmer	S05Y41	S05Y12
Cooling Tower	C13G41	C13G12				Soap Line	S06Y41	S06Y12
Cooling Water	C14G41	C14G12	___LBS	L01Y41	L01Y22	Soft Water	S07G41	S07G12
___C°	C15Y41	C15Y22	Lab Air	L02G41	L02G22	Soft Water	S08Y41	S08Y12
			Lab Air	L03Y41	L03Y22	Solar	S09Y41	S09Y22
Deionized Water	D01G41	D01G12	Liquid Soap	L04G41	L04G12	Solvent	S10Y41	S10Y12
Demineralized Water	D02G21	D02G12	Low Pressure	L05G41	L05G12	Sprinkler Fire	S11R41	S11R12
Diesel Oil	D03Y41	D03Y12	Low Pressure	L06Y41	L06Y12	Sprinkler Water	S12R41	S12R12
Digester Gas	D04Y41	D04Y12	Low Press. Cond.	L07Y21	L07Y12	Standpipe	S13R41	S13R12
Discharge	D05G41	D05G12	Low Press. Steam	L08Y21	L08Y12	Steam	S14Y41	S14Y22
Distilled Water	D06G41	D06G12	Low Temp.	L09Y41	L09Y12	Storm Drain	S15G41	S15G12
Dom. Cold Water	D07G41	D07G12				Supply	S16G41	S16G22
Dom. Hot Water	D08Y41	D08Y12	Main Drain	M01G41	M01G12	Supply	S17Y41	S17Y22
Dom. H.W. Recirc.	D09Y21	D09Y12	Make Up	M02G41	M02G22			
Domestic	D10G41	D10G12	Med. Pressure	M03Y41	M03Y12	Tank Drain	T01G41	T01G12
Domestic	D11Y41	D11Y12	Med. Press. Cond.	M04Y21	M04Y12	Tempered Water	T02Y41	T02Y12
Drain	D12G41	D12G22	Med. Press. Steam	M05Y21	M05Y12	Tower Water	T03G41	T03G12
Drain	D13Y41	D13Y22				Trap Seal Primer	T04G21	T04G12
Drinking Water	D14G41	D14G12	Natural Gas	N01Y41	N01Y12	Treated Water	T05G41	T05G12
Dual Temp.	D15Y41	D15Y12	Natural Gas	N0XY14	N/A			
			Non Potable Water	N02G21	N02G12	Vacuum	V01G41	V01G22
Electric Traced	E01Y21	E01Y12				Vacuum	V02Y41	V02Y22
Exhaust	E02G41	E02G22	Oil	O01Y41	O01Y22	Vent	V03G41	V03G22
Exhaust	E03Y41	E03Y22	Oxygen	O02G41	O02G22	Vent	V04Y41	V04Y22
			___PSI	P01Y41	P01Y22	Waste Water	W01G41	W01G12
Fan Coil Return	F01Y21	F01Y12	Plant Air	P02G41	P02G12	Water	W02G41	W02G22
Fan Coil Supply	F02Y21	F02Y12	Plant Air	P03Y41	P03Y12	Water	W03Y41	W03Y22
Fire Prot. Water	F03R41	F03R12	Plumbing Vent	P04G41	P04G12			
Fire Standpipe	F04R41	F04R12	Pool	P05Y41	P05Y22			
Freon	F05G41	F05G22						



## Medical Gas & Specialty Pipe Markers

### ORDERING CODES

#### Medical Gas & Specialty Pipe Markers

LEGEND	CODE NO.
Carbon Dioxide	MEDG-CD
Medical Air	MEDG-MA
Medical Vacuum	MEDG-MV
Nitrogen	MEDG-NI
Nitrous Oxide	MEDG-NO
Oxygen	MEDG-OX
N2O Evacuation	SPEG-NE
Argon	SPEG-AR
Compressed Air	SPEG-CA
Helium	SPEG-HE
Lab Air	SPEG-LA
Lab Vacuum	SPEG-LV

### PRODUCT DESCRIPTION

Medical gas and specialty pipe markers are 6 mil thick ( $\pm 0.05$  mil), flexible soft vinyl with permanent pressure sensitive acrylic adhesive. Characters are  $3/8$ " high vinyl ink, silk-screened on marker. Medical gas markers are manufactured to conform with CAN/CSA Z305.1.92 for non flammable medical gas piping systems and CGSB standard 1-GP-12C for colour coding.

Medical & specialty cards are 14" high by 5" wide and have 14 legends. Each card provides for continuous 360° identification with overlap on up to 4" dia. pipe. Markers can be cut to provide various quantities of labels to suit pipe sizes smaller than 4".

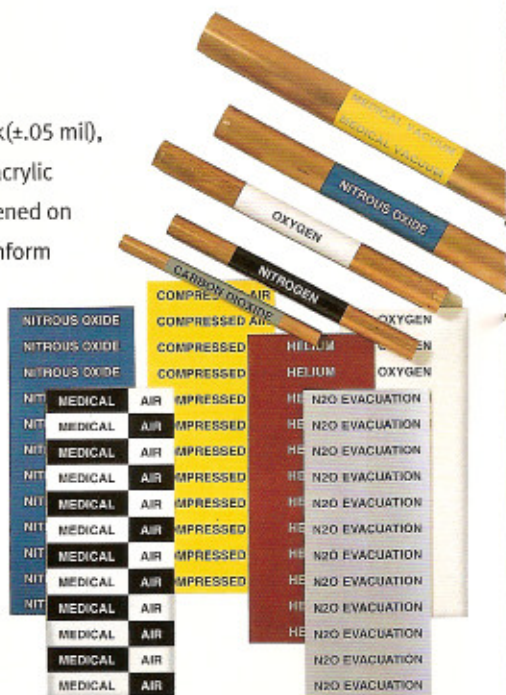

## Underground Marking Tape

### ORDERING CODES

#### Underground Marking Tape

LEGEND	CODE NO.
Electric	UGMT-EL
Fiber Optic	UGMT-FO
Gas	UGMT-GA
Oil	UGMT-OI
Pipeline	UGMT-PI
Sewer	UGMT-SE
Telephone	UGMT-TP
Television	UGMT-TV
Water	UGMT-WA

### PRODUCT DESCRIPTION

Underground marking tape provides an economical method of locating buried services in addition to eliminating potential hazards of excavating in unmarked areas. The intent is for the tape to be exposed during excavation creating an awareness of buried services below. Tape should be installed as close to the surface as possible for optimum protection and detectability. The warning legend typically reads "CAUTION GAS\* LINE BURIED BELOW". \*(See legend table for options.)

Non detectable tape is 4 mil low density polyethylene, with organic pigmented lead free black ink. Detectable tape has vinyl ink printed on a 35 gauge aluminum core encased in a protective plastic jacket and allows for "tracing" of the buried line with the use of a surface detector.

To order detectable style add a "D" at the front of the code no. as follows: D-UGMT-SE



Both styles are stocked or available with various legends in 3" wide by 1000' long rolls, 6" wide rolls are available as a special order item.

# Plumbing & Heating System Valve Tags

## PRODUCT DESCRIPTION

S.M.S. stock brass valve tags are 1 1/4" dia. with 3/8" high stamped, black paint filled characters in .025" thick yellow brass. Stock plastic valve tags are 1 1/4" sq. by 1/16" thick white plastic with engraved 3/8" black characters. All tags come complete with a 1/8" dia. by 4" long brass plated steel bead chain. Stock tags are available in sets, as noted, with numbers only or with 3/16" identifiers "P" or "H". Add on or fill-in sets are also available from stock in any increment of 25 tags, (i.e. 26-50, 101-125, 251-275 etc.)

S.M.S. can also provide special order tags in a variety of shapes, sizes, materials and numbering or lettering sequences.

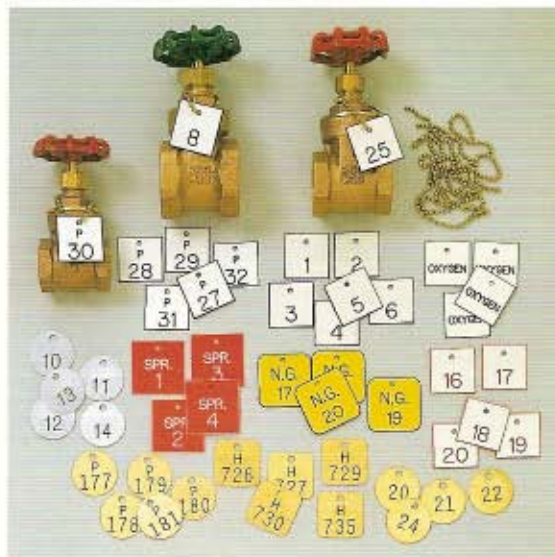

## ORDERING CODES

### Valve Tags

SET	RD. BRASS	SQ. PLASTIC
1-25	RB1-25	SP1-25
1-50	RB1-50	SP1-50
1-100	RB1-100	SP1-100
101-200	RB101-200	SP101-200
201-300	RB201-300	SP201-300
301-400	RB301-400	SP301-400
401-500	RB401-500	SP401-500

### SPECIAL TAG ORDERING INFORMATION:

- RP: Round Plastic
- SB: Square Brass
- RS: Round Stainless
- SS: Square Stainless
- RA: Round Aluminum
- SA: Square Aluminum

# Engraved I.D. Plates & Specialty Tags

## PRODUCT DESCRIPTION

S.M.S. I.D. plates are typically 1/16" thick two-ply coloured plastic. Characters are engraved through the durable primary colour to expose the contrasting background colour.

I.D. plates are custom made to order and provide precise quality identification of equipment such as pumps, fans, starters, and air handling units. The size of each plate will be determined by the quantity and size of characters. I.D. plates can be ordered with peel and stick adhesive back or holes for hanging or securing with screws.



## ORDERING CODES

### Engraved I.D. Plates & Specialty Tags

PRIMARY COLOUR	CHARACTER COLOUR	COLOUR CODE NO.
Black	White	101
White	Black	102
Red	White	103
White	Red	104
Blue	White	105
Green	White	106
Orange	White	107
Brown	White	108

### REQUIRED ORDERING INFORMATION:

- character size
- colour code
- adhesive
- drilled

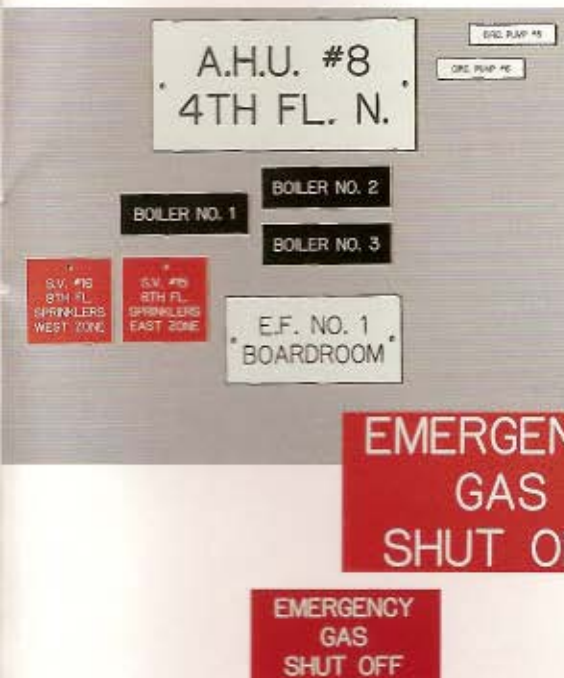



## I.D. Stencils & Marking Accessories

### ORDERING CODES

### PRODUCT DESCRIPTION

#### I.D. Stencils & Marking Accessories

1 1/2" Roller Complete	SMA-101
1 1/2" Roller Refill	SMA-102
3" Roller Complete	SMA-103
3" Roller Refill	SMA-104
Large Ink Pad	SMA-105
Black Ink Quart Can	SMA-106
White Ink Quart Can	SMA-107
Brown Ink Quart Can	SMA-108
Blue Ink Quart Can	SMA-109
Green Ink Quart Can	SMA-110
Orange Ink Quart Can	SMA-111
Red Ink Quart Can	SMA-112
Yellow Ink Quart Can	SMA-113
Solvent Quart Can	SMA-114
Fountain Roller Complete	SMA-115
Fountain Roller Refill	SMA-116

S.M.S. I.D. stencils are 0.01" thick plastic Mylar, with computer designed and cut 1" or 2" high standard size characters. A range of 1/2" through 10" character sizes are available.

All stencils are custom made and provide economical identification of piping systems and ductwork. Other common uses include identification of company property such as tool cribs, scaffolding and equipment. An inventory of coloured inks along with rollers, ink pads and cleaning solvent is available to provide a complete stencil marking outfit.



## Identification System Specification

Contractor shall provide and install a complete identification system as specified below and as manufactured by Smillie McAdams Summerlin Limited of Pickering, Ontario.

### Pipe Systems

Contractor shall identify all pipe or pipe covering with Coil-Mark or adhesive style building service pipe markers. All identification shall incorporate direction of flow arrows and the manufacturer's standard system designations.

Identification must be applied at intervals not greater than 40 ft., adjacent to valves, behind access doors, at changes in direction and where pipes pass through walls or floors.

All pipe identification shall be installed in accordance with the manufacturer's recommendations.

### Valves

Contractor shall identify all valves by means of a 1 1/4" diameter brass tag with 3/8" stamped black paint filled characters, or a 1 1/4" square engraved two-ply plastic tag with 3/8" black characters on white background, tags to be consecutively numbered and secured to valves by a brass bead chain.

Contractor shall provide and mount for owner a typed valve directory in a black document frame, listing valve number, location and service. Individual fixture valves need not be identified.

### Equipment

Contractor shall identify all equipment such as, but not limited to fans, pumps, motors, AHU's and their related starters by means of an engraved two-ply plastic I.D. plate.

Equipment I.D. plates shall have 3/8" white characters on black background; starter I.D. plates shall be as above with 1/8" characters. All plates shall be sized to accommodate required description, type of equipment, number and service. Locate plates conspicuously and secure with self tapping sheet metal screws where possible, or double sided adhesive tape. Recognized abbreviations will be acceptable,

other proposed abbreviations to be approved by this consultant.

### Ductwork

Contractor shall identify all Ductwork with 2" stencils using black or white ink to contrast surface being identified.

Identification locations shall conform to guidelines for pipe and shall indicate flow medium, function and direction.

Contractor shall ensure stencilling is performed in a neat, quality manner. Upon completion of project contractor shall turn over one complete set of stencils as used on the project to the building owner.



Smillie McAdams Summerlin Ltd.  
900 McKay Road, Unit 1  
Pickering, Ontario  
Canada L1W 3X8  
Phone: (905) 428-6900  
Fax: (905) 428-6598